

3717348COM TV Stand

Date of Purchase ___ / ___ / ___

Lot Number:

B343717348COM1

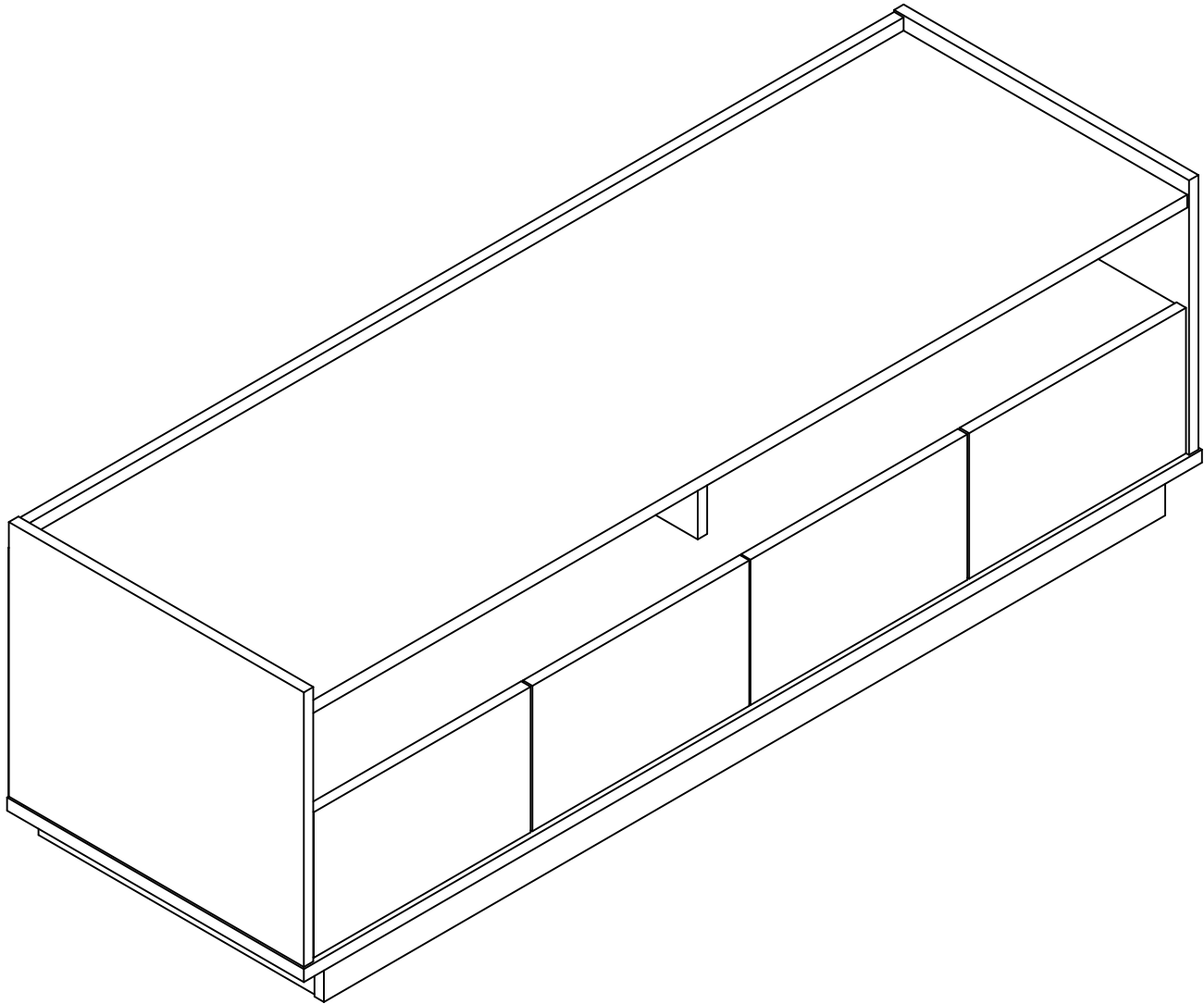

THIS INSTRUCTION BOOKLET CONTAINS **IMPORTANT** SAFETY INFORMATION. PLEASE READ AND KEEP FOR FUTURE REFERENCE.

Do Not Return This Product!

Contact our customer service team for help first.

Call: 1-800-489-3351 (toll free)

Monday-Friday 9am - 5pm CST

Visit: www.ameriwoodhome.com



WARNING

- Unit can tip over causing severe injury or death.
- Anchor unit to stud in wall (if instructed to).
- Do Not allow children to climb on unit.
- Put heavy items on lower shelves or drawers.

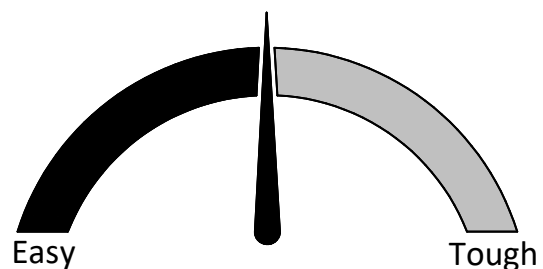

Assembly Difficulty Meter

Contact Us!

Do NOT return this product!

Contact our friendly customer service team first for help.

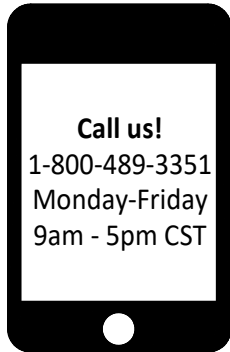

Visit ameriwoodhome.com to view the limited warranty valid in the U.S. and Canada.

Assembly Tips



Helpful Hints

PEOPLE NEEDED FOR ASSEMBLY: 2

- Open your item in the area you plan to keep it to avoid excessive heavy lifting.
- Identify, sort and count the parts before attempting assembly.
- Compression dowels are lightly tapped in with a hammer.
- Slides are labeled with a **R** (right) and **L** (left) for proper placement.
- Make sure to always face the point on the top of the Cam Lock towards the outer edge.
- Use all the nails provided for the back panel and spread them out equally.
- Back panel must be used to make sure your unit is sturdy.
- Do NOT use harsh chemicals or abrasive cleaners on this item.
- Never push, pull, or drag your furniture.

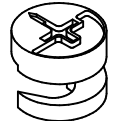

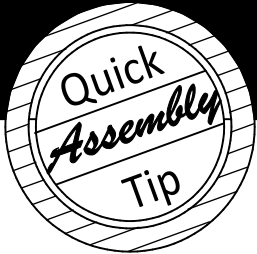

Before You Start

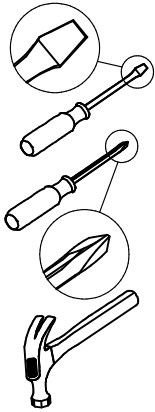

- ✓ Read through each step carefully and follow the proper order
- ✓ Separate and count all your parts and hardware
Parts are labeled on the surface or edge of the part
- ✓ Give yourself enough room for the assembly process
- ✓ Have the following tools: Flat Head Screwdriver, #2 Phillips Head Screwdriver and Hammer
- ✓ Caution: If using a power drill or power screwdriver for screwing, please be aware to slow down and stop when screw is tight. Failure to do so may result in stripping the screw.

Cam Lock Fastening System

This Cam Lock Fastening System will be used throughout the assembly process.

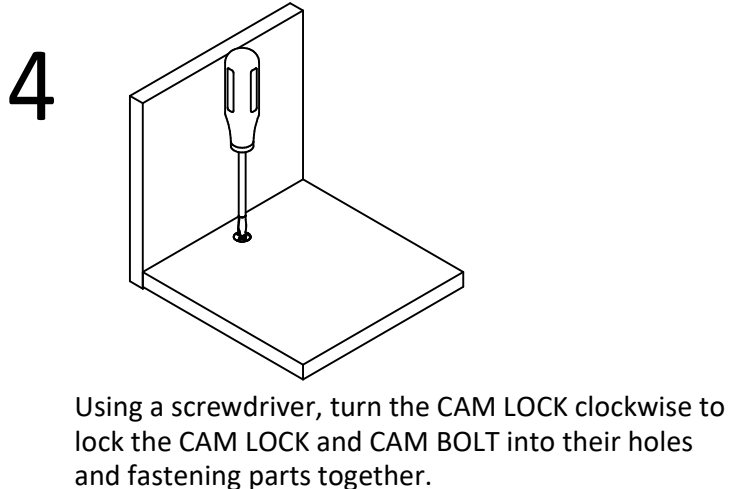
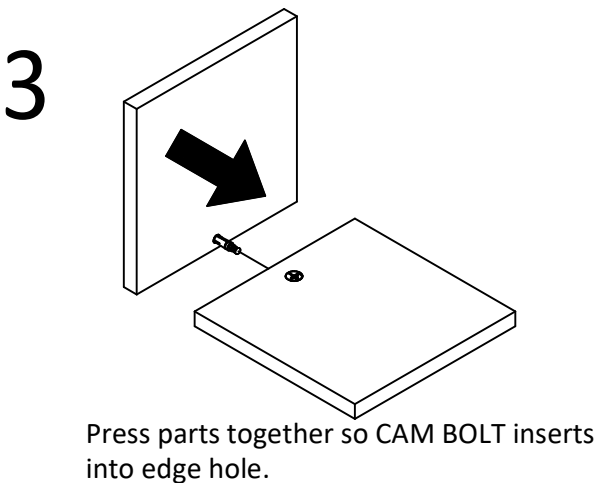
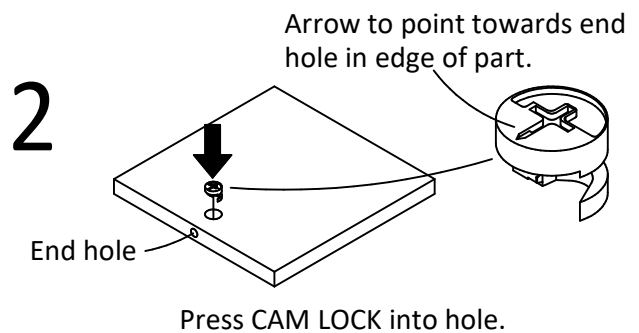
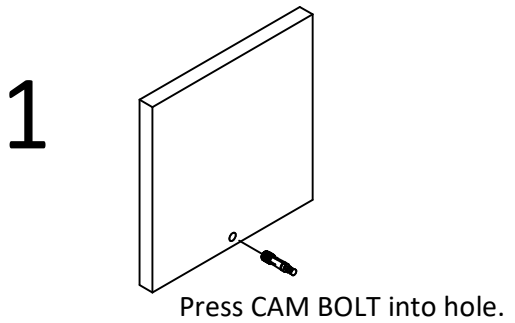

Please Note:

You may need to lightly tap the wood dowels into the holes during your assembly process.

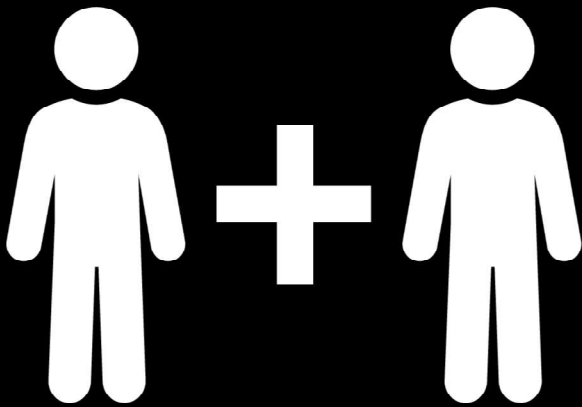
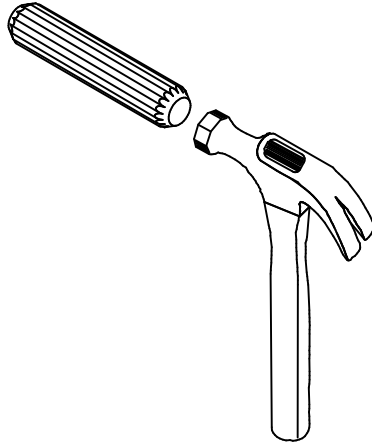

2 PEOPLE NEEDED FOR ASSEMBLY

**2 PERSONAS NECESITADAS
PARA LA ASAMBLEA**

**2 PERSONNES NÉCESSAIRES
POUR L'ASSEMBLAGE**

CAUTION: Failure to use 2 people for assembly could result in unit damage or personal injury.

PRECAUCIÓN: Si no se utilizan 2 personas para el ensamblaje, se pueden producir daños en la unidad o lesiones personales.

ATTENTION: Échec d'utiliser 2 personnes pour l'assemblage peut causer du dommage au meuble ou causer des blessures.

Board Identification

Not actual size

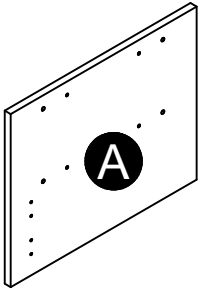

Left Panel
33717348010

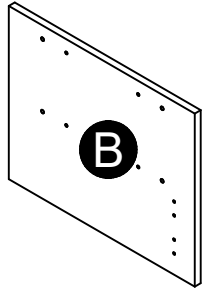

Right Panel
33717348020

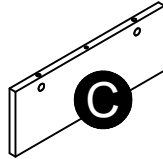

Upper Partition
33717348030

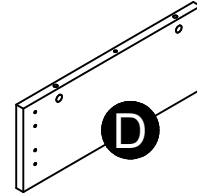

Lower Partition
33717348040

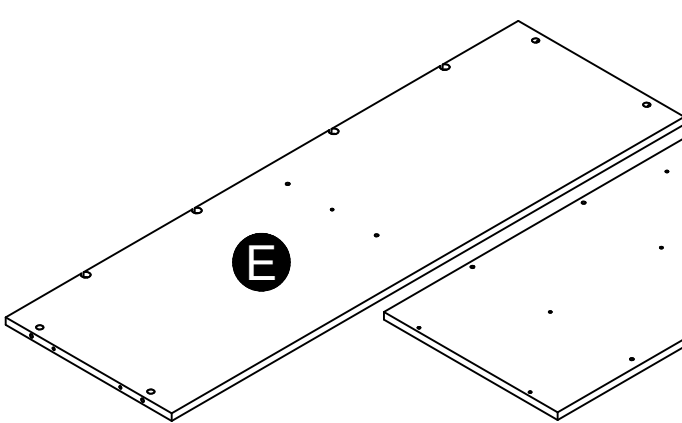

Top
33717348050

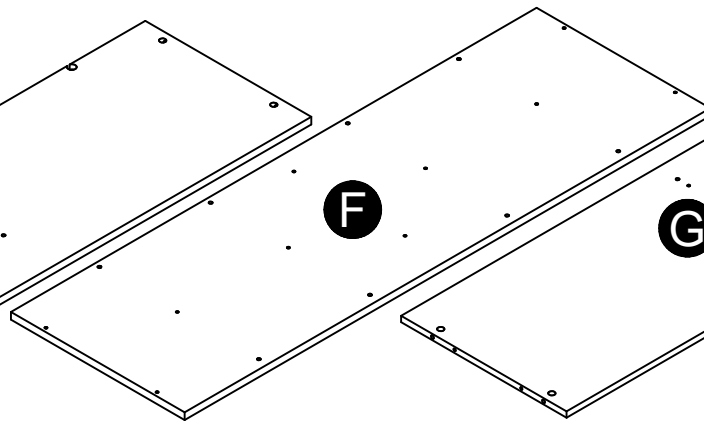

Bottom
33717348060

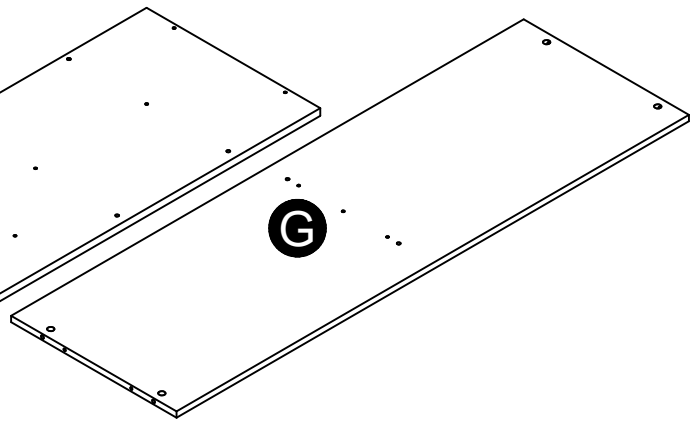

Shelf
33717348070

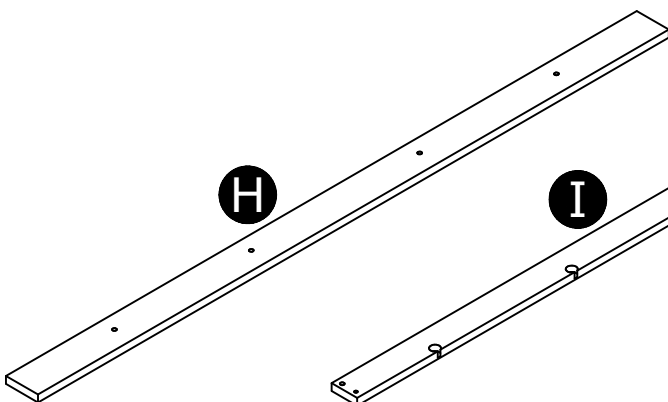

Top Rail
33717348080

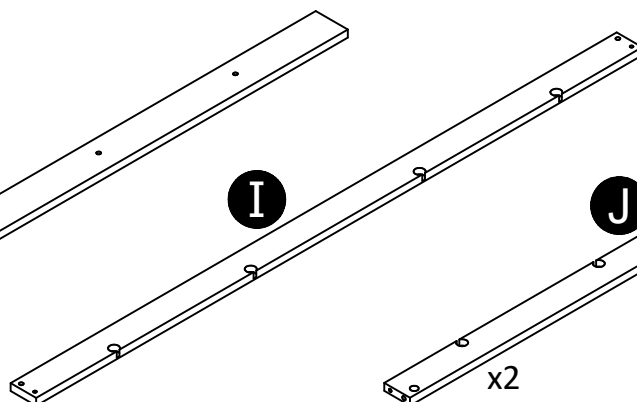

Front Rail
33717348090

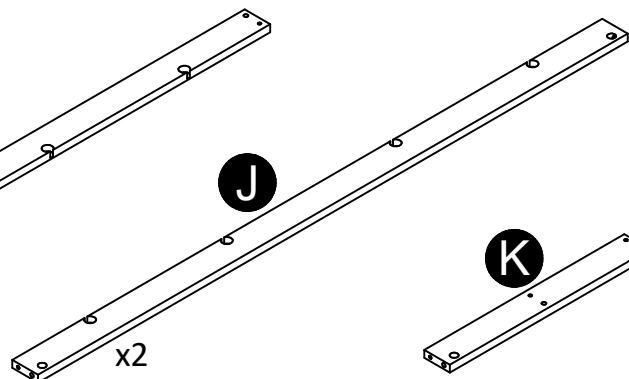

x2
Rear Rail
33717000100

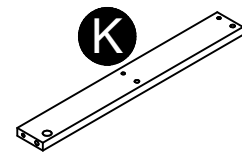

Left Rail
33717348110

Board Identification

Not actual size

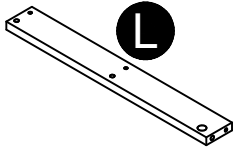

Right Rail
33717348120

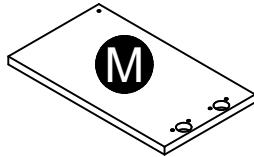

Left Outer Door
33717355130

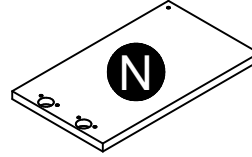

Right Outer Door
33717355140

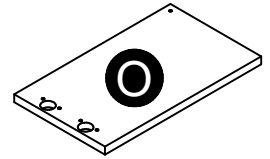

Left Inner Door
33717355150

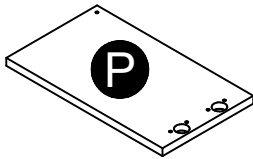

Right Inner Door
33717355160

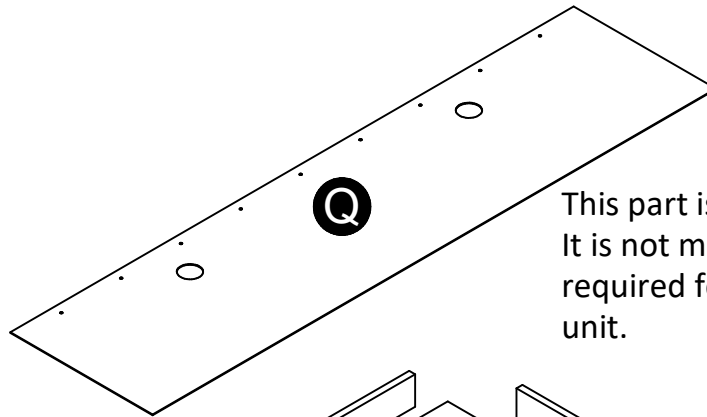

Back Panel
K371734800

This part is paperboard construction.
It is not made from wood, but is
required for the assembly of your
unit.

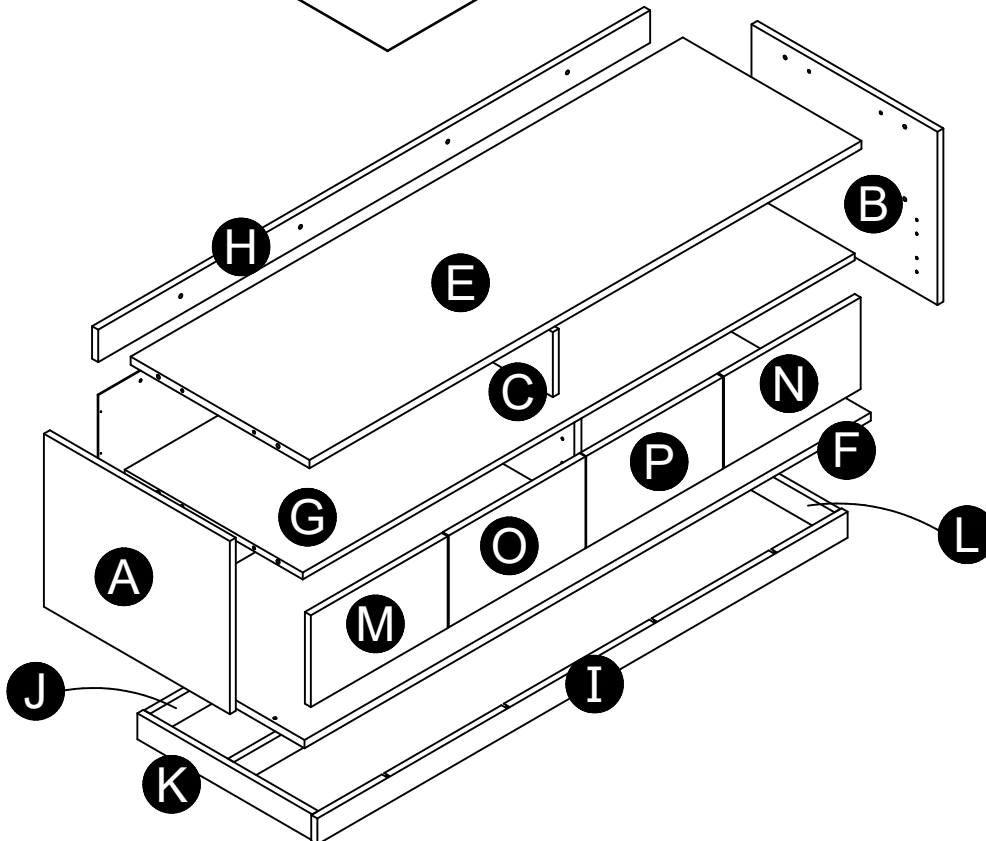

Part List

Note: Your model may have extra hardware included.

Actual Size

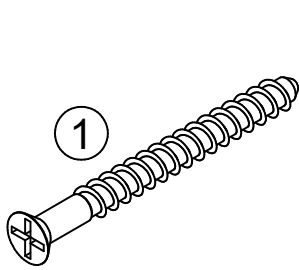

(x8)
#A23030
confirmat screw

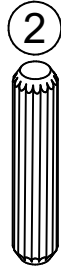

(x16)
#A21670
wood dowel

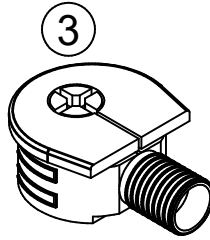

(x16)
#A22760
quicklock



(x4)
#A89370
door bumper



(x9)
#A12120
#8 x 7/16"
panhead screw

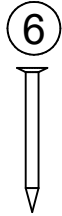

(x17)
#A21110
nail

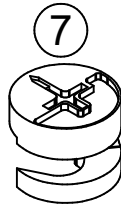

(x18)
#A22700
cam lock



(x18)
#A22710
cam bolt

Not Actual Size

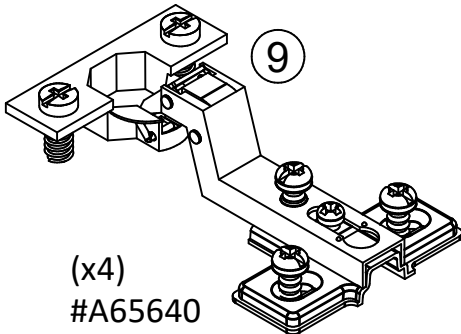

(x4)
#A65640
hinge

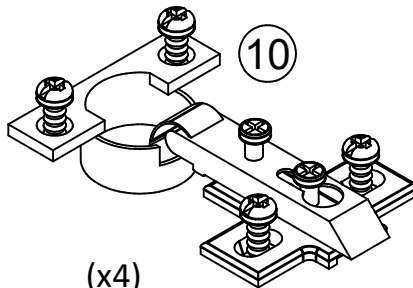

(x4)
#A65615
hinge

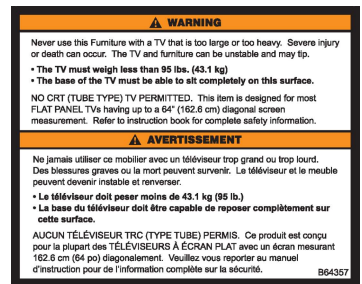

(x1)
#B64357
TV Warning Label

STEP 1

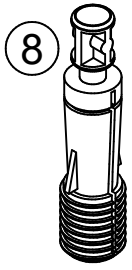

(x8)

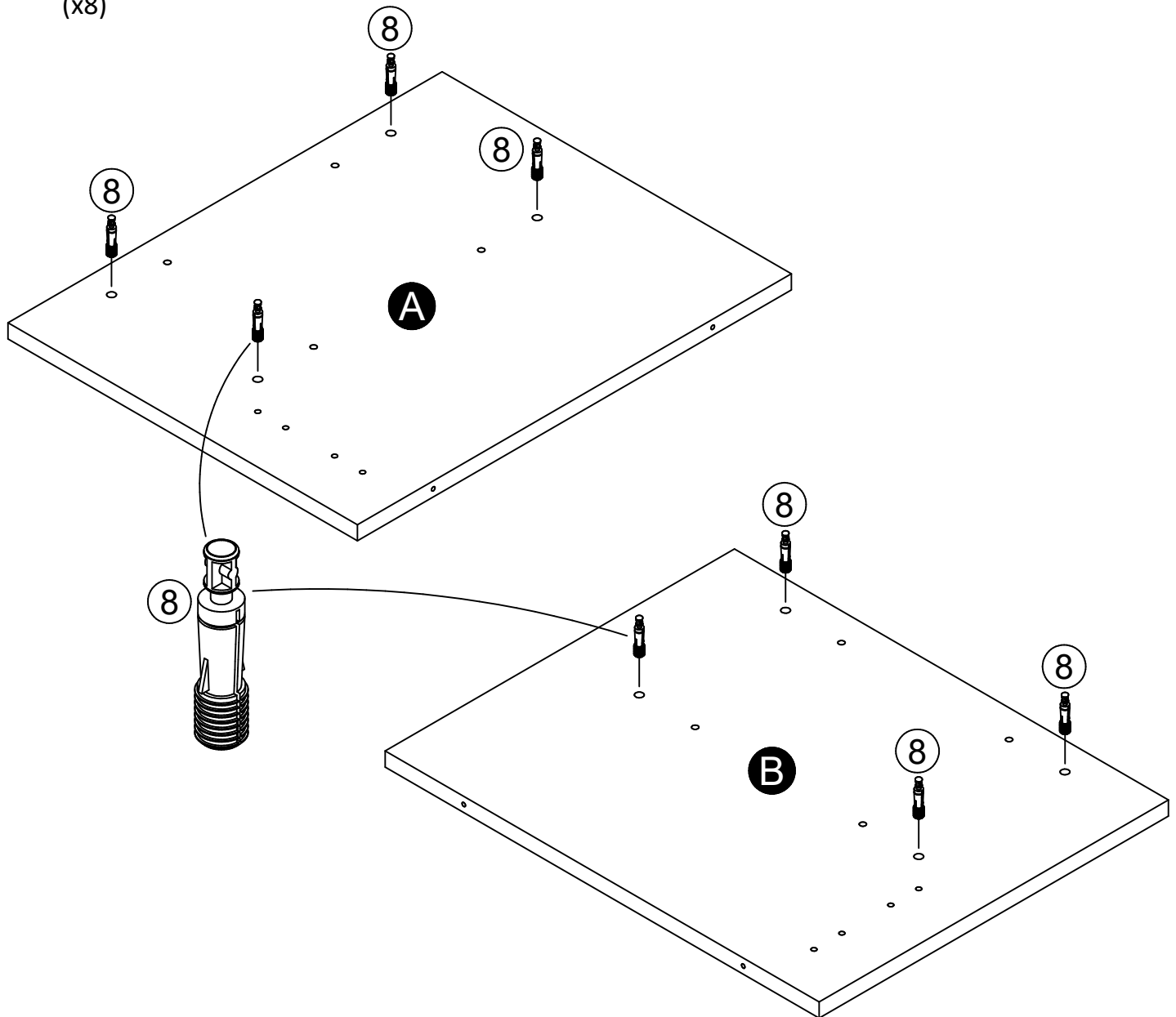
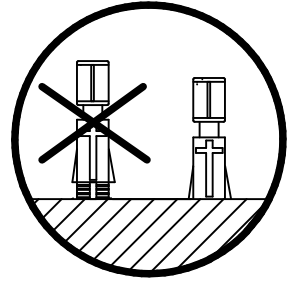

STEP 2

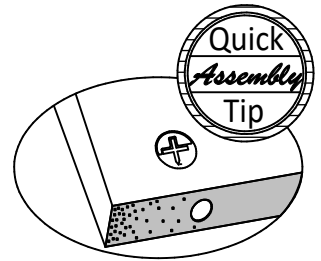
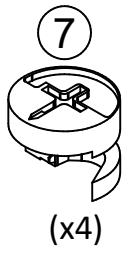
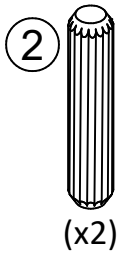

Proper orientation of CAM LOCK

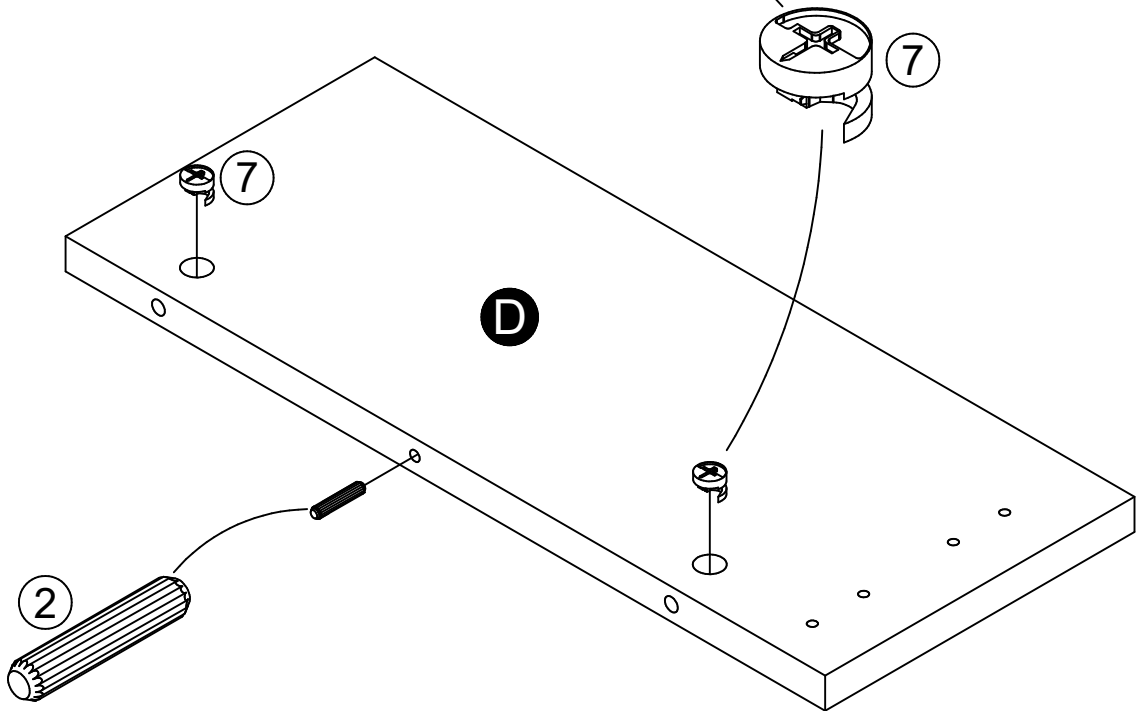
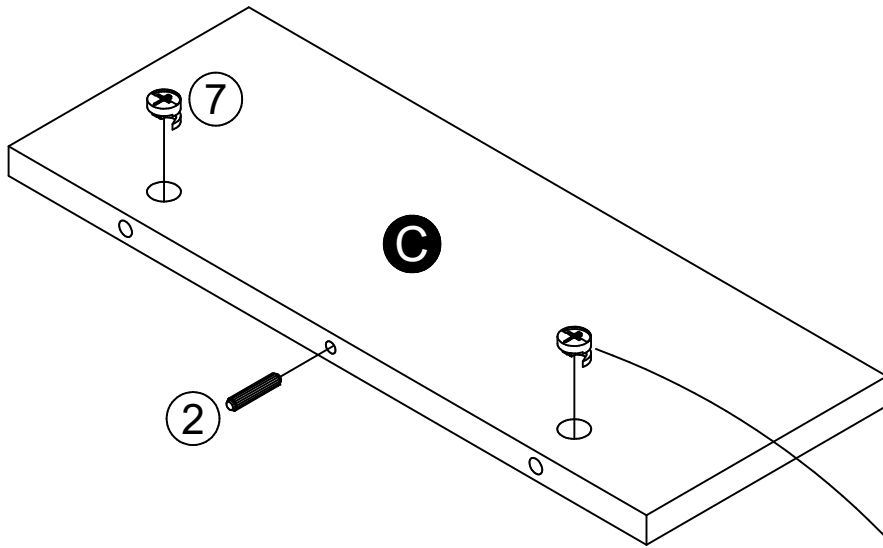

STEP 3

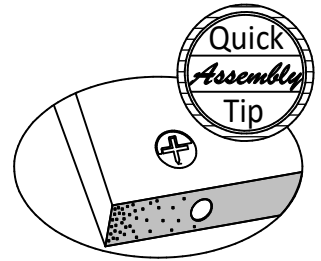
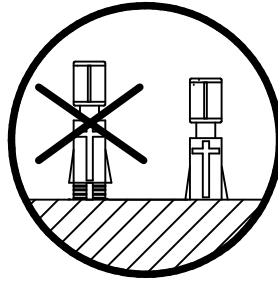
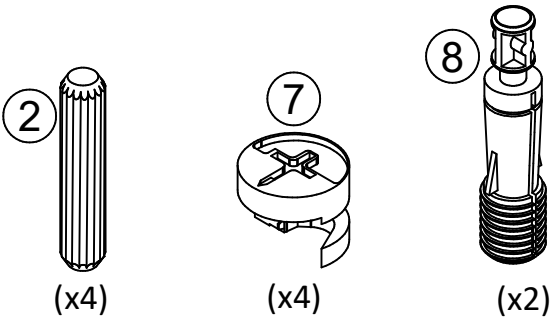

Quick Assembly Tip
Proper orientation of CAM LOCK

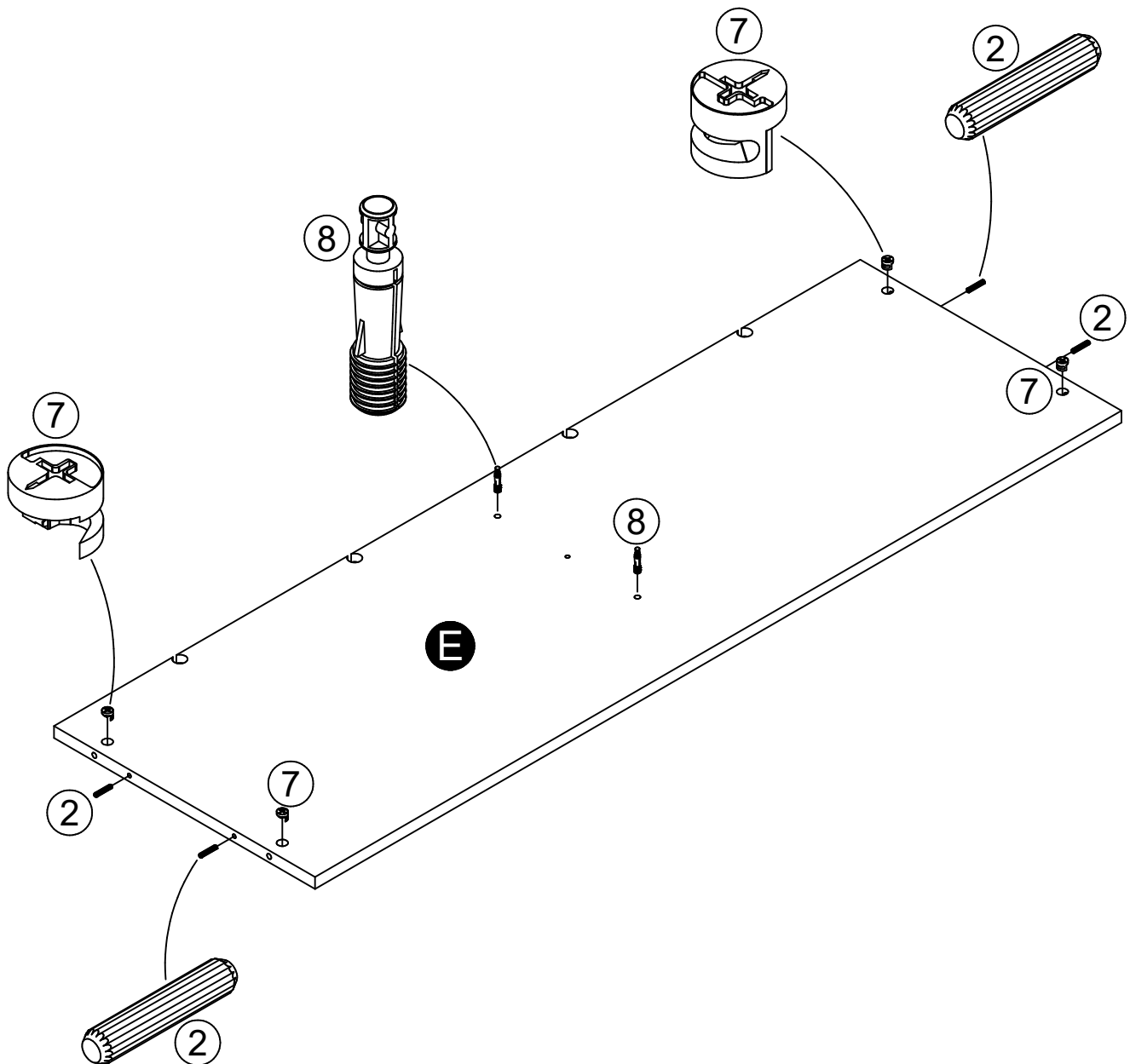

STEP 4

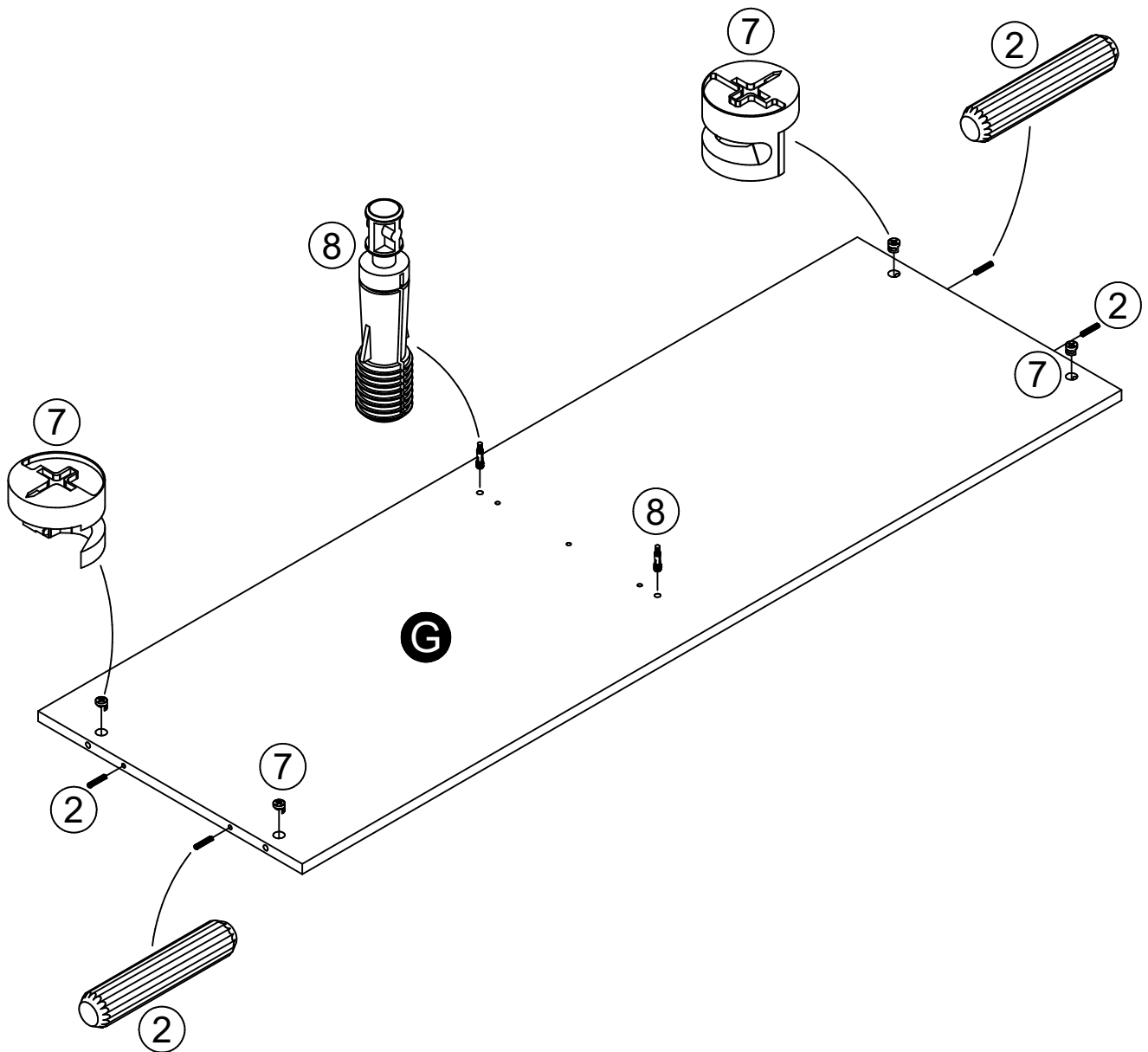
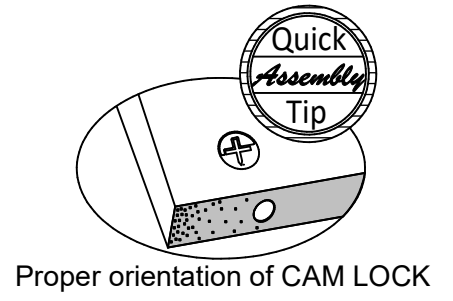
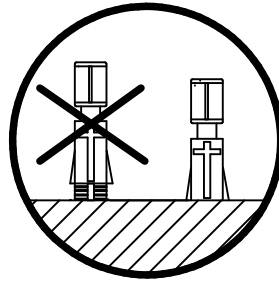
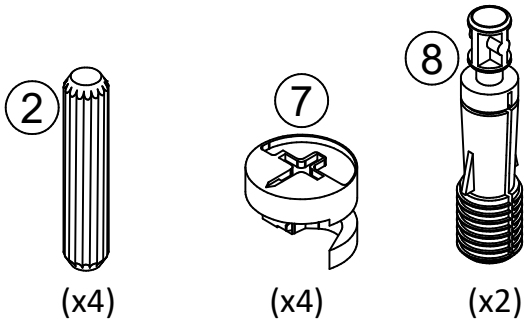

STEP 5

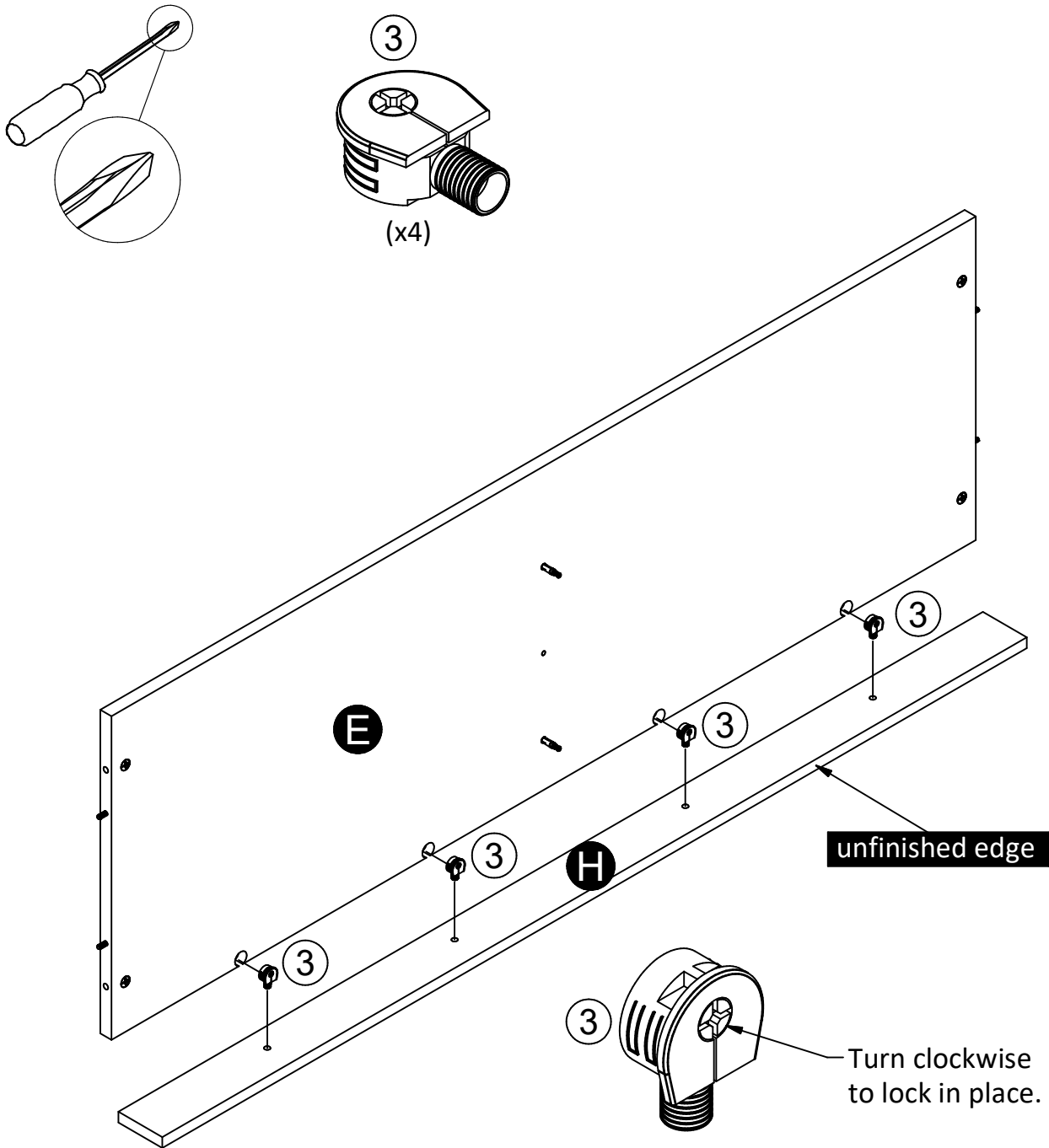

Press four quickloc fasteners (3) into holes in top (E). With top rail (H) laying flat with larger holes (4 holes) facing up, press top (E) onto top rail (H) so quickloc fasteners (3) engage into holes. Turn fasteners clockwise to lock both parts together.

STEP 6

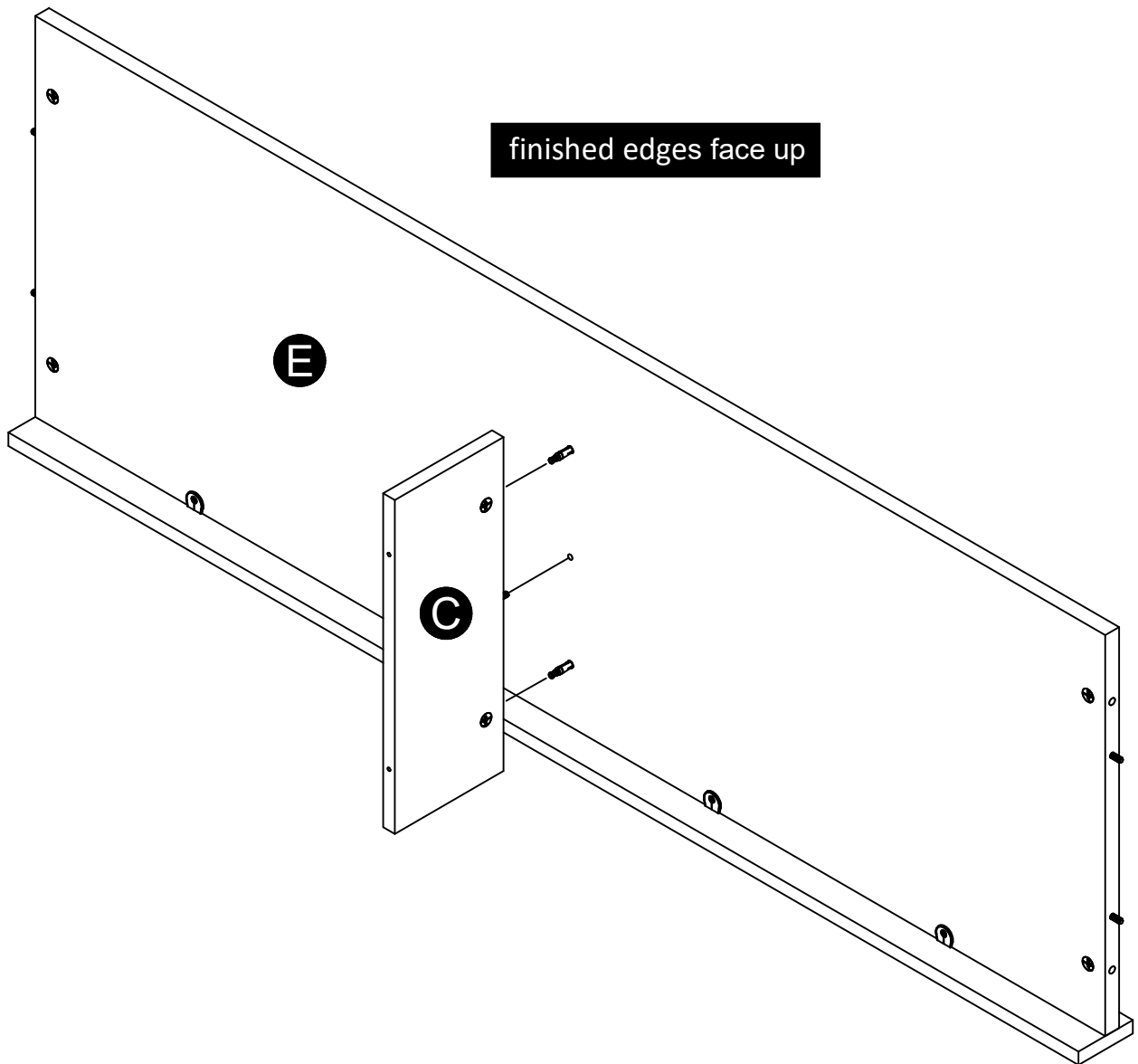
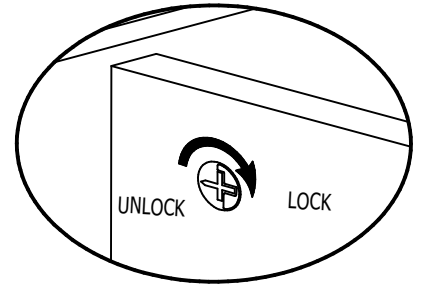
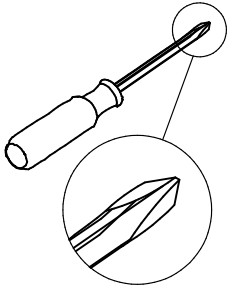

STEP 7

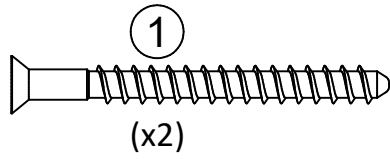
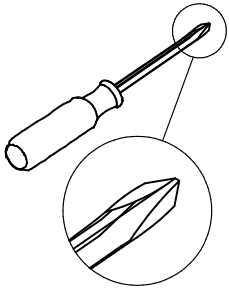

finished edges face up

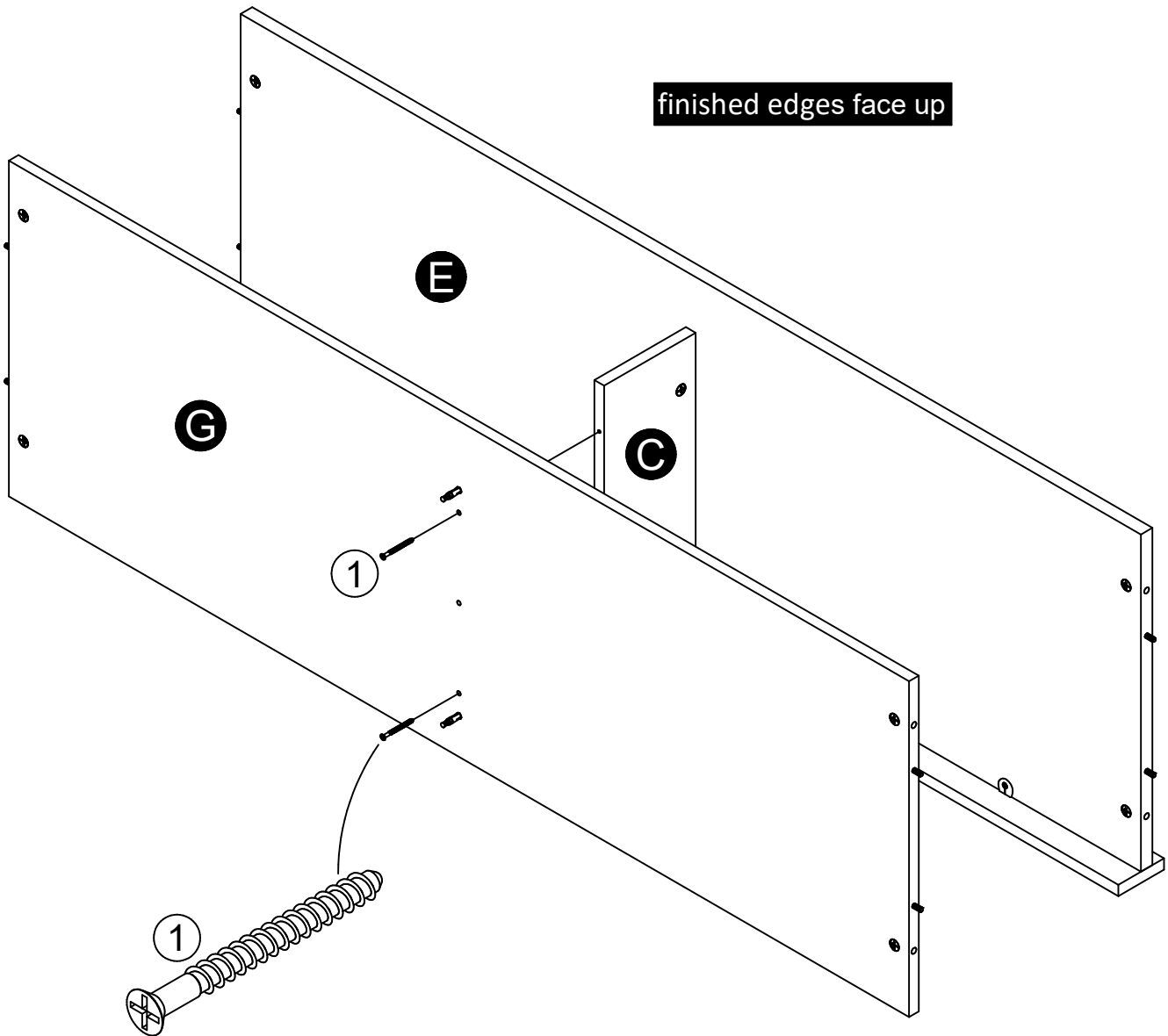

STEP 8

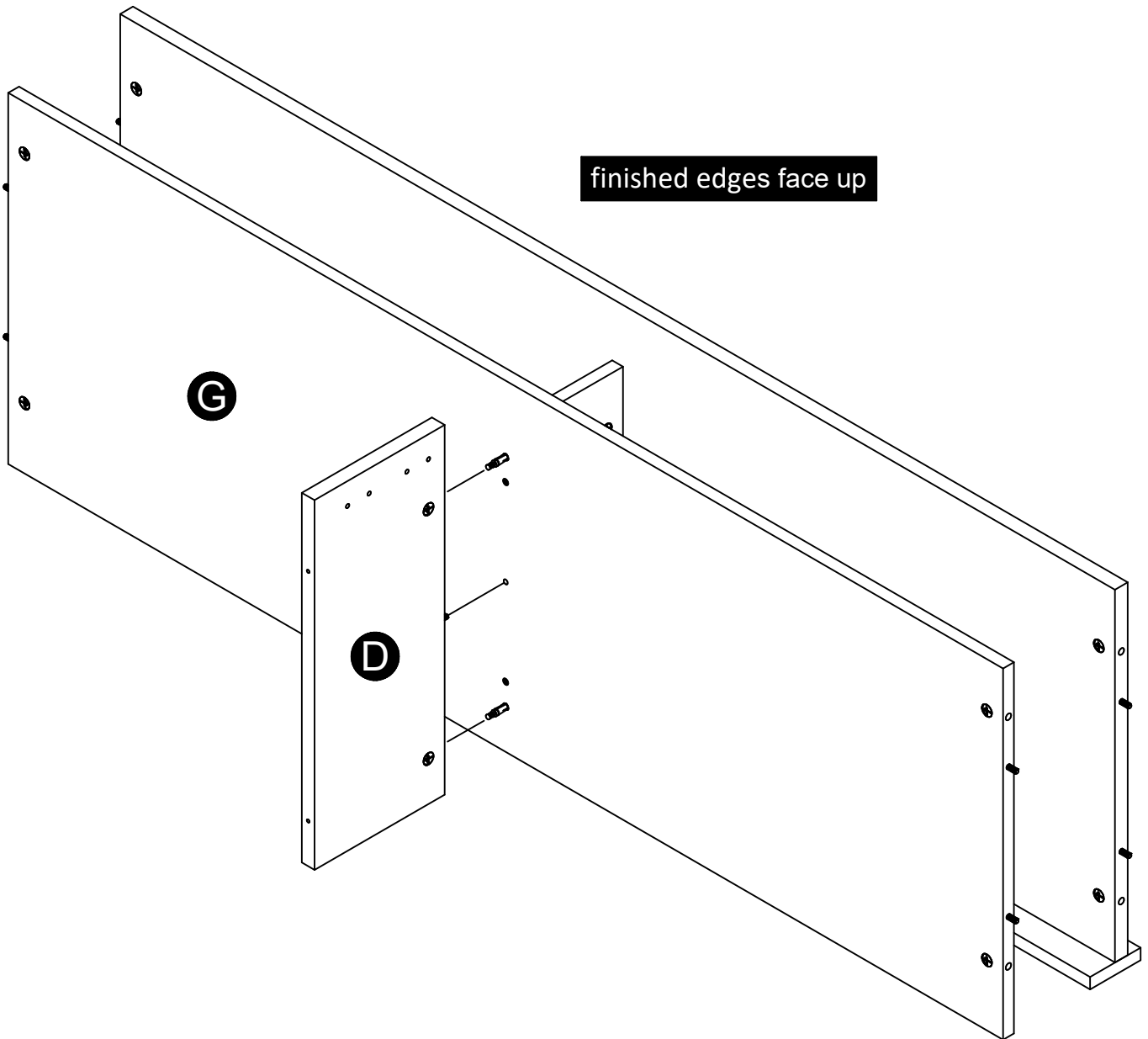
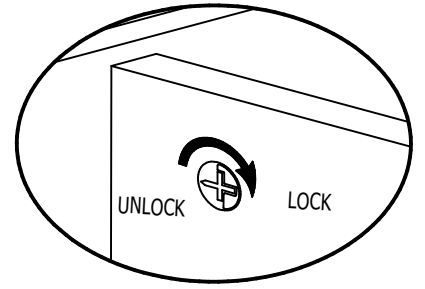
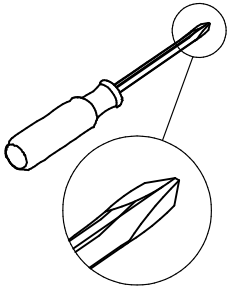

STEP 9

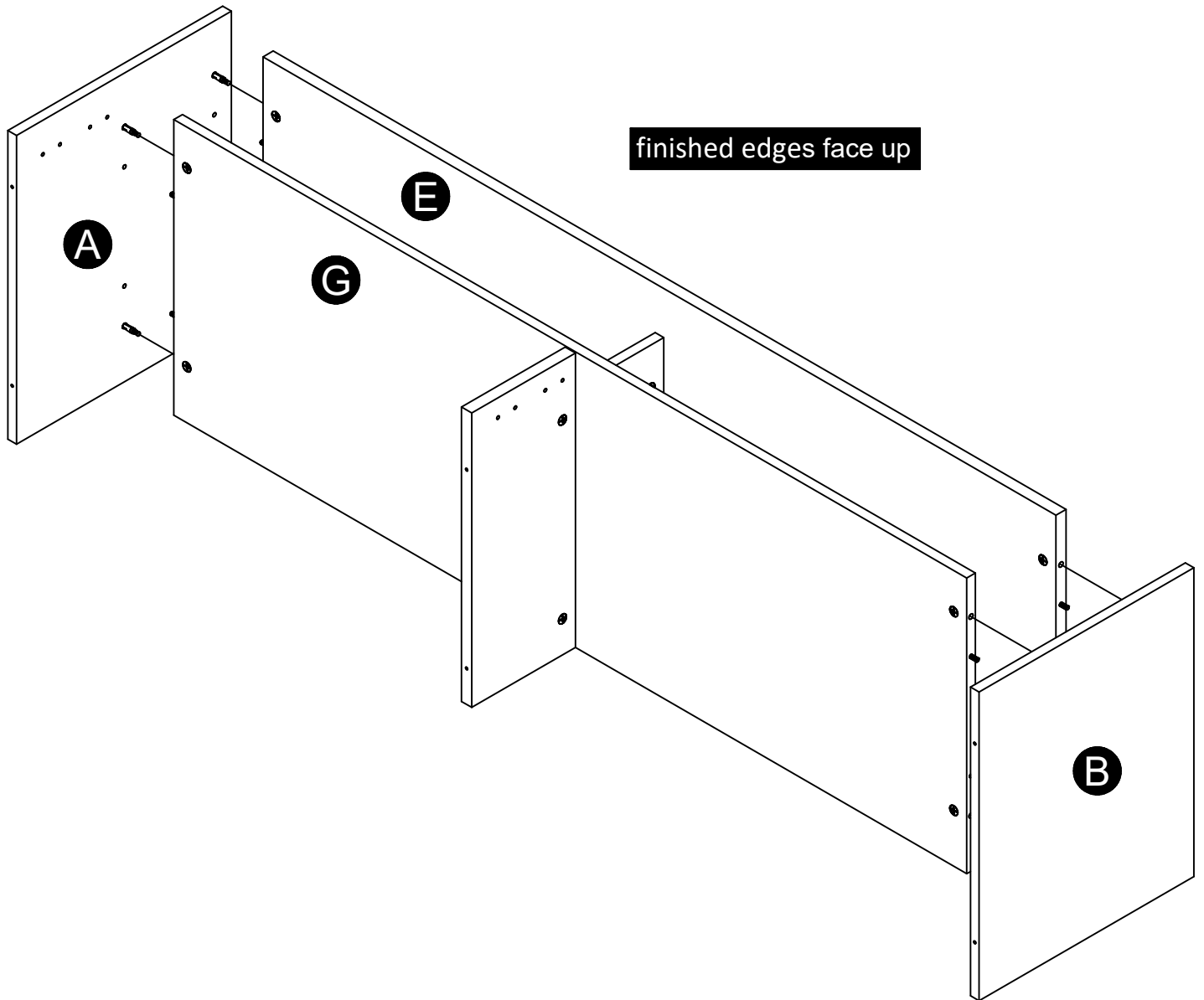
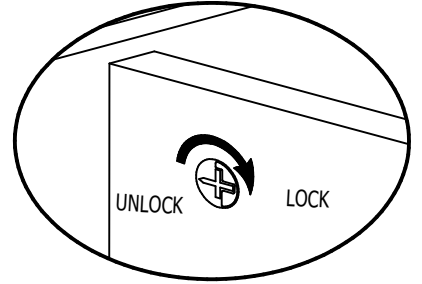
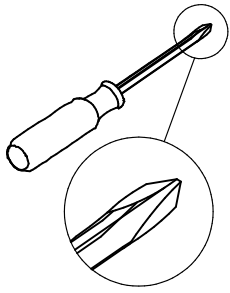

STEP 10

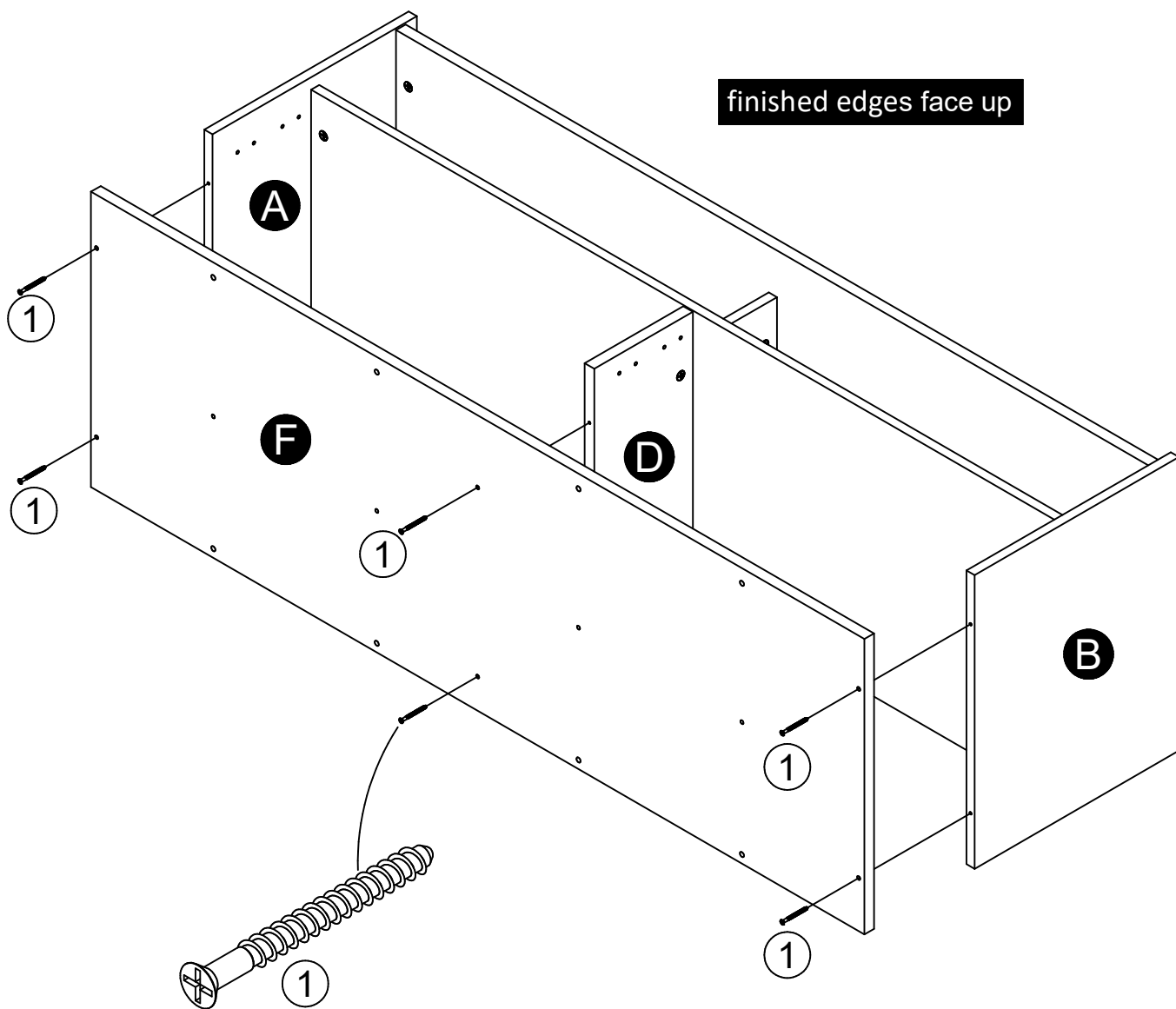
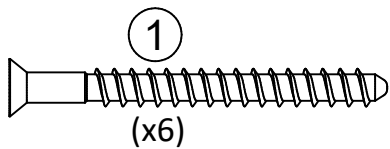
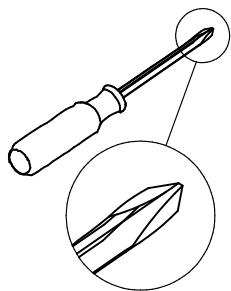

STEP 11

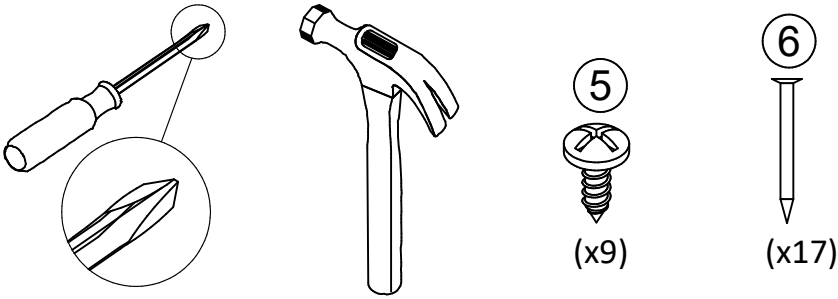

IMPORTANT! THE BACK PANEL IS A STRUCTURAL PART OF THIS UNIT AND MUST BE INSTALLED PROPERLY.

With the help of another person, carefully turn your unit onto its front. Position back panel as shown. Align squarely with edges of bottom, left panel and right panel. Using screws (5), start each screw as shown but do not fully tighten. Make sure back panel is aligned squarely and nail (6) straight down into the three edges as shown. Now fully tighten the screws (5).

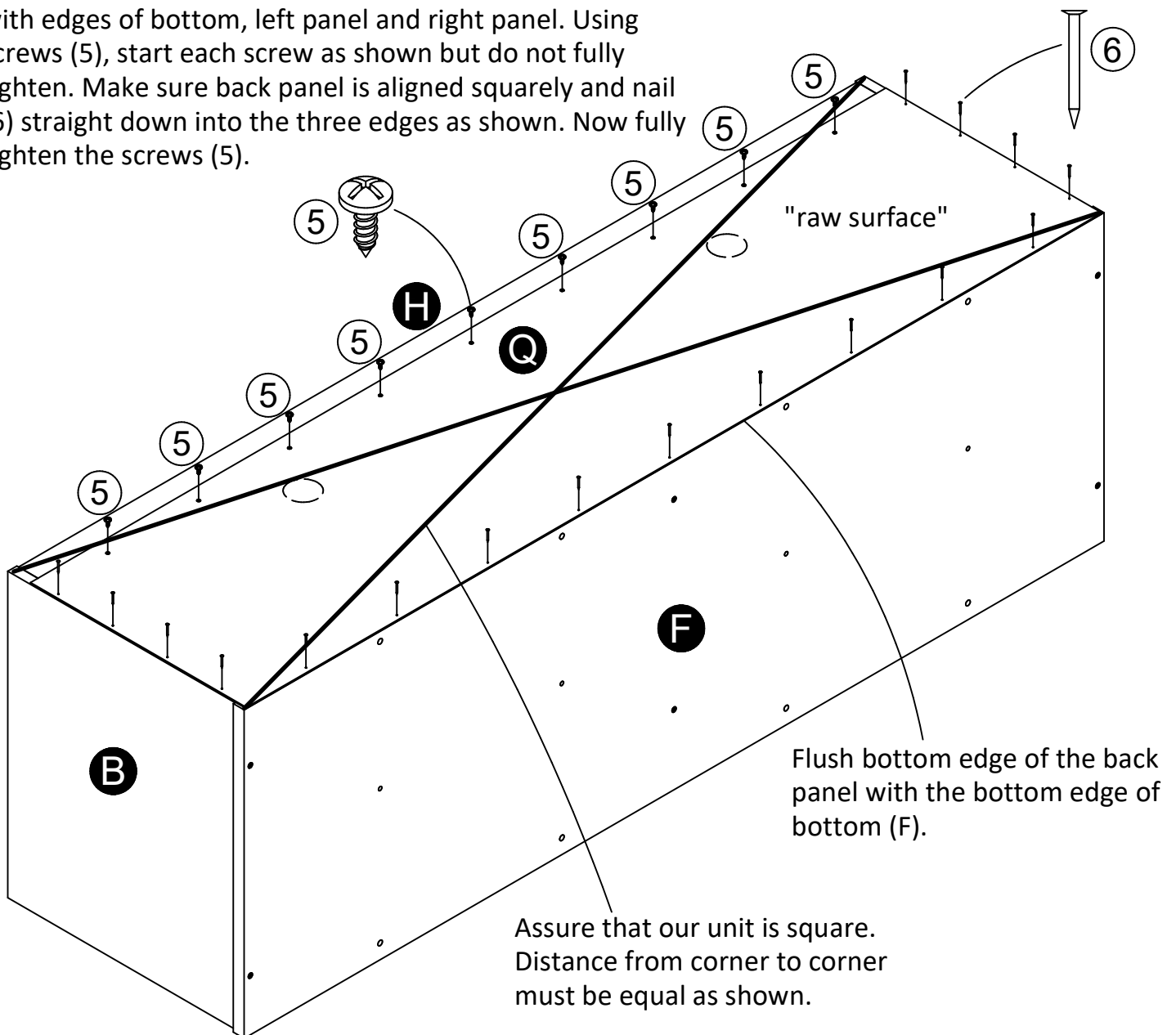

STEP 12

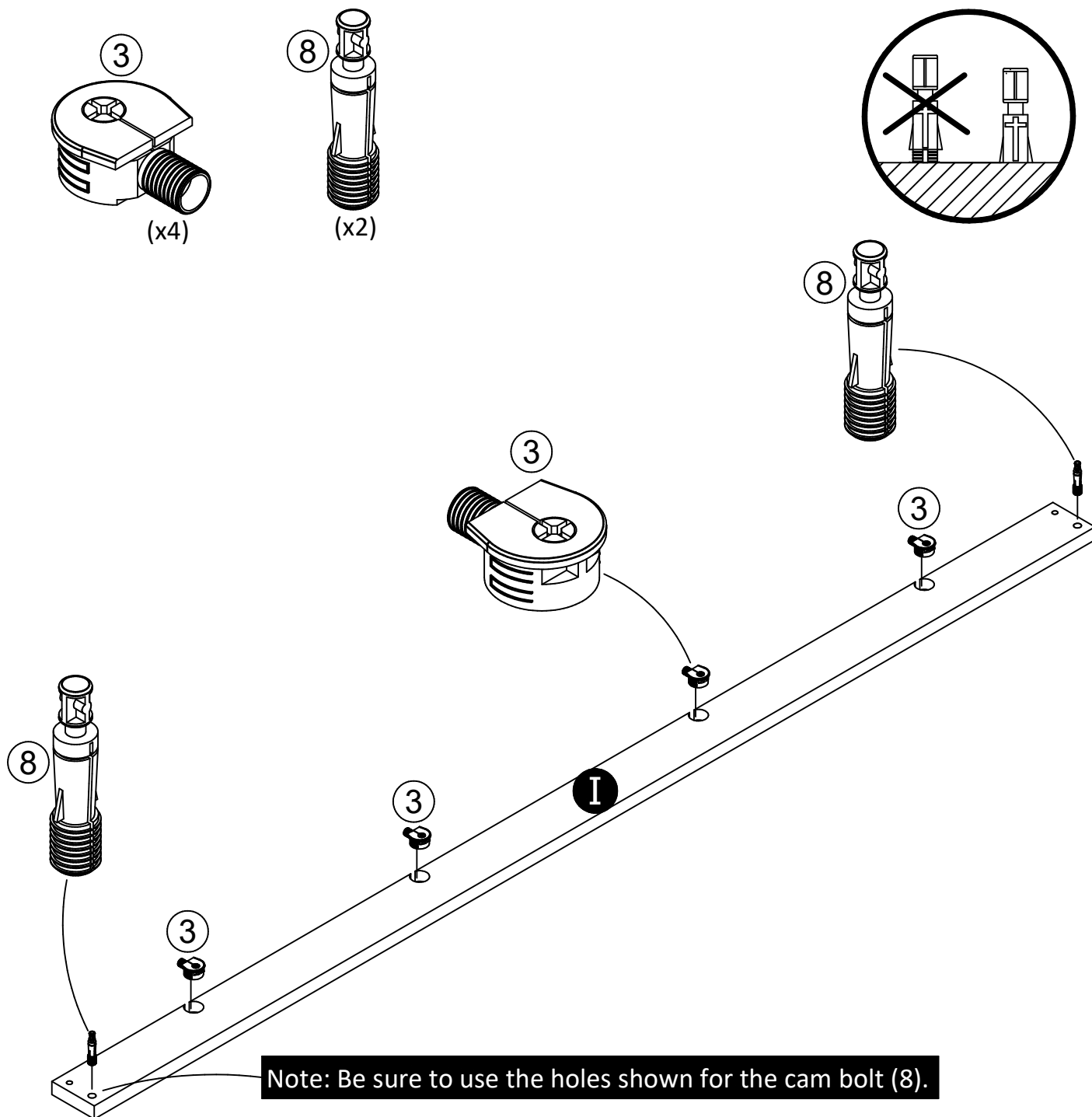

STEP 13

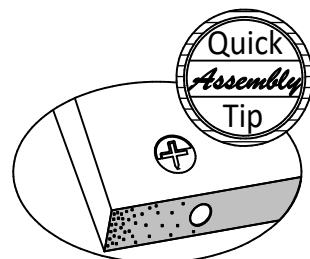
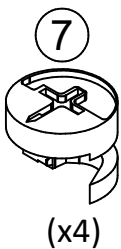
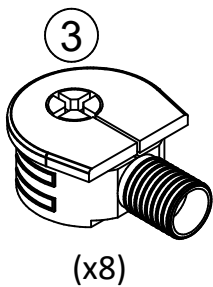
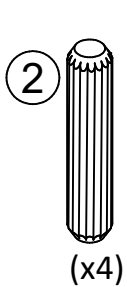

Proper orientation of CAM LOCK

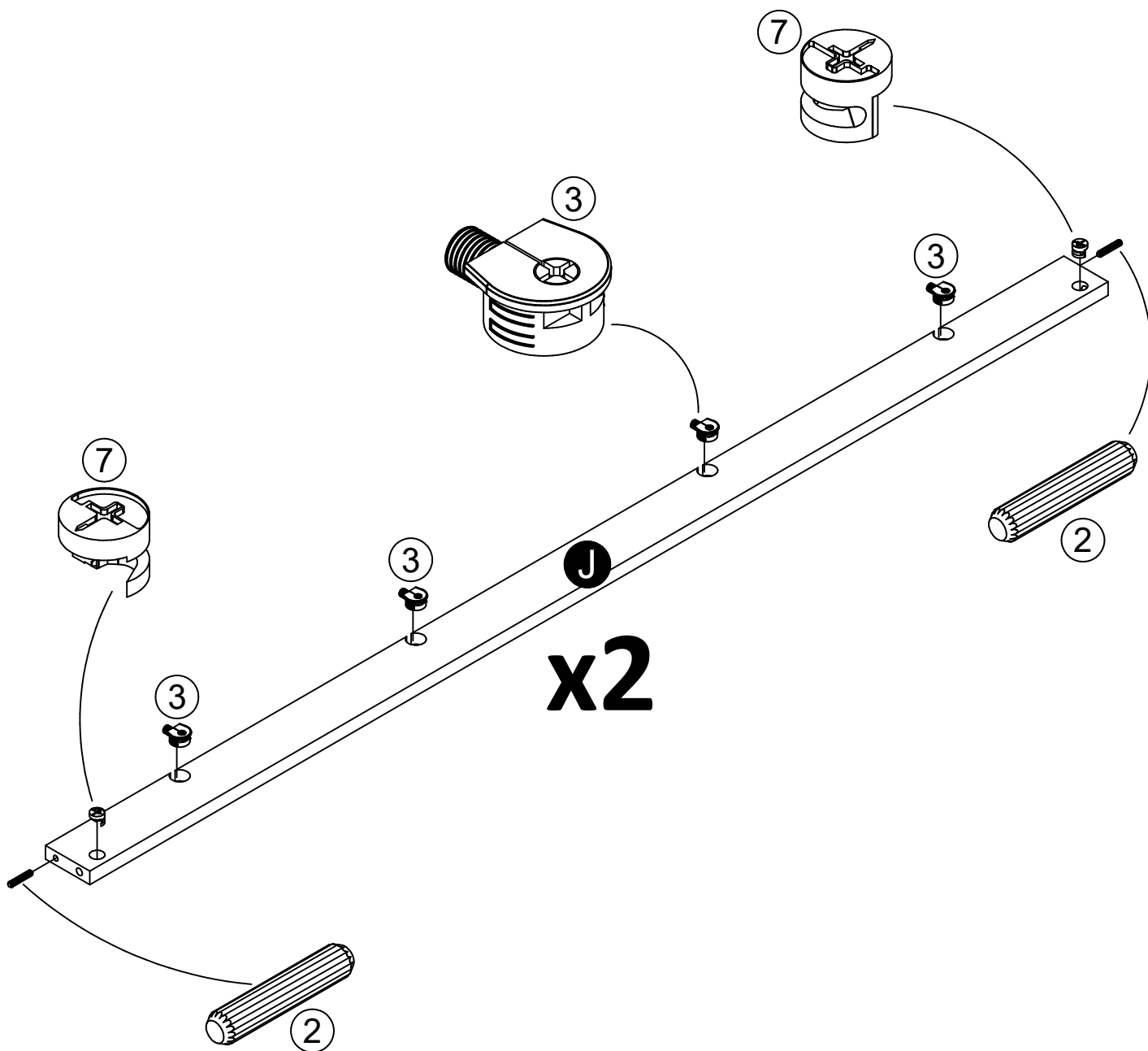

STEP 14

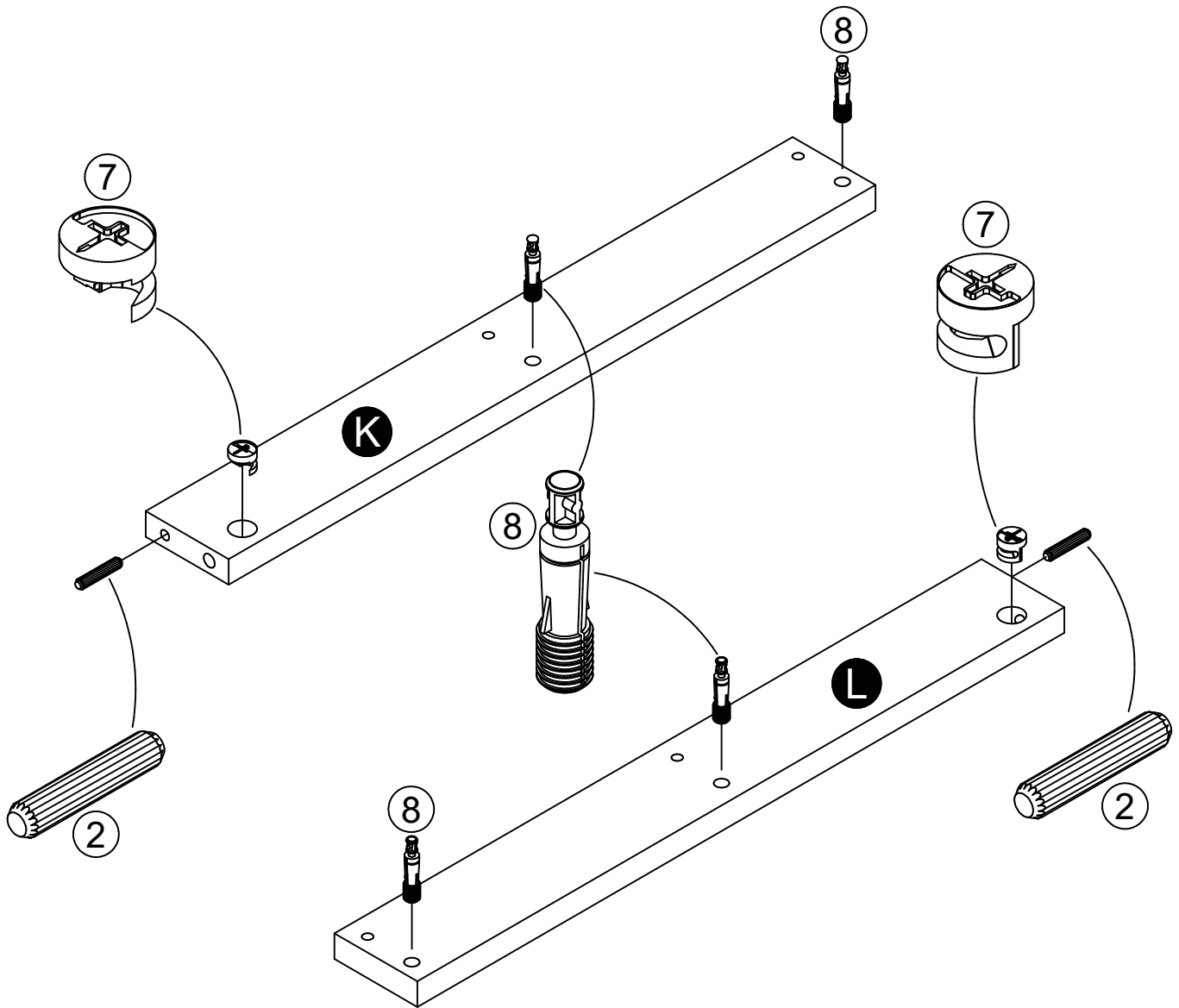
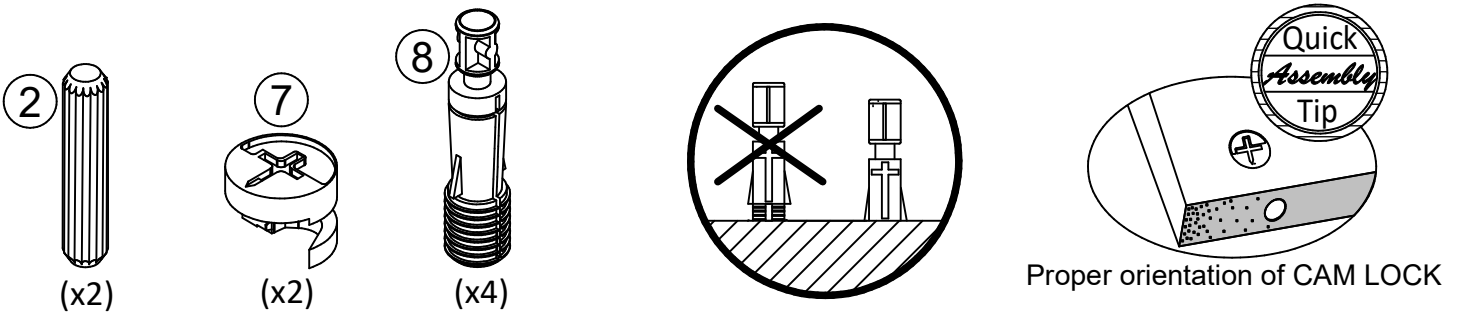

STEP 15

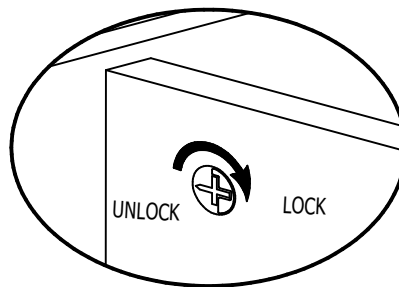
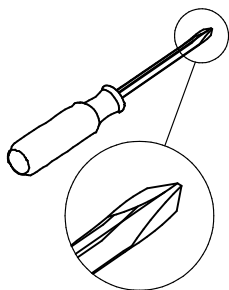

Attach the left rail (K) and right rail (L) to the rear rails (J) as shown and then attach front rail (I) to the left and right rails (K&L).

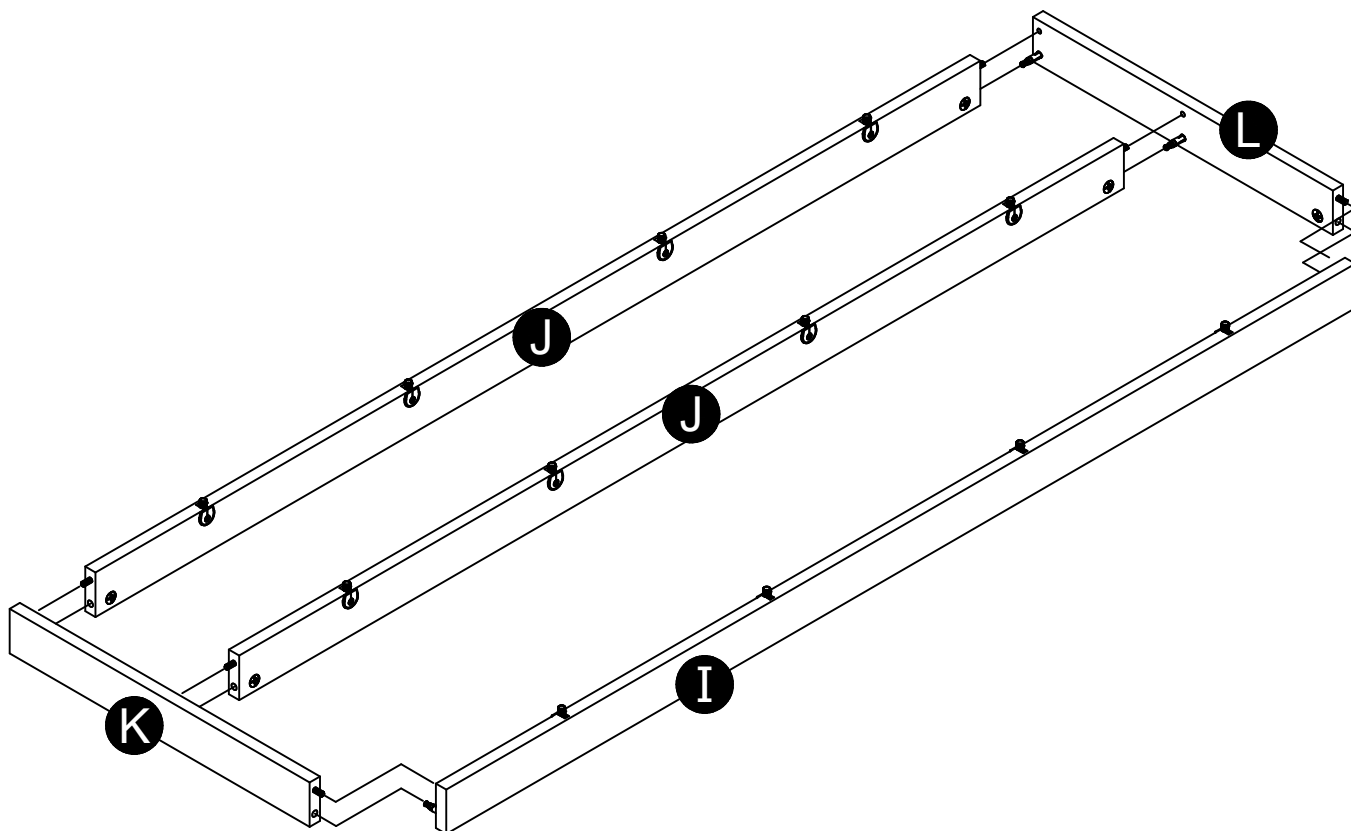

STEP 16

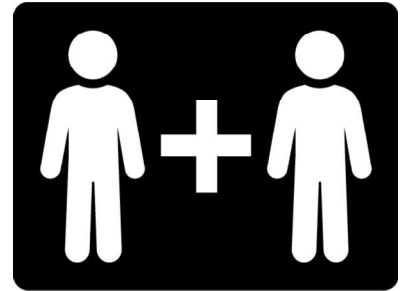
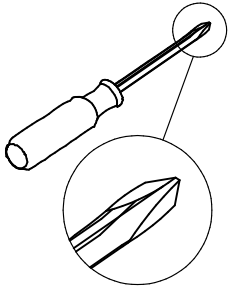

Carefully position unit on its top as shown. Position base rail component from previous step onto bottom (F) so the quickloc fasteners (3) engage the holes and fasten into place.

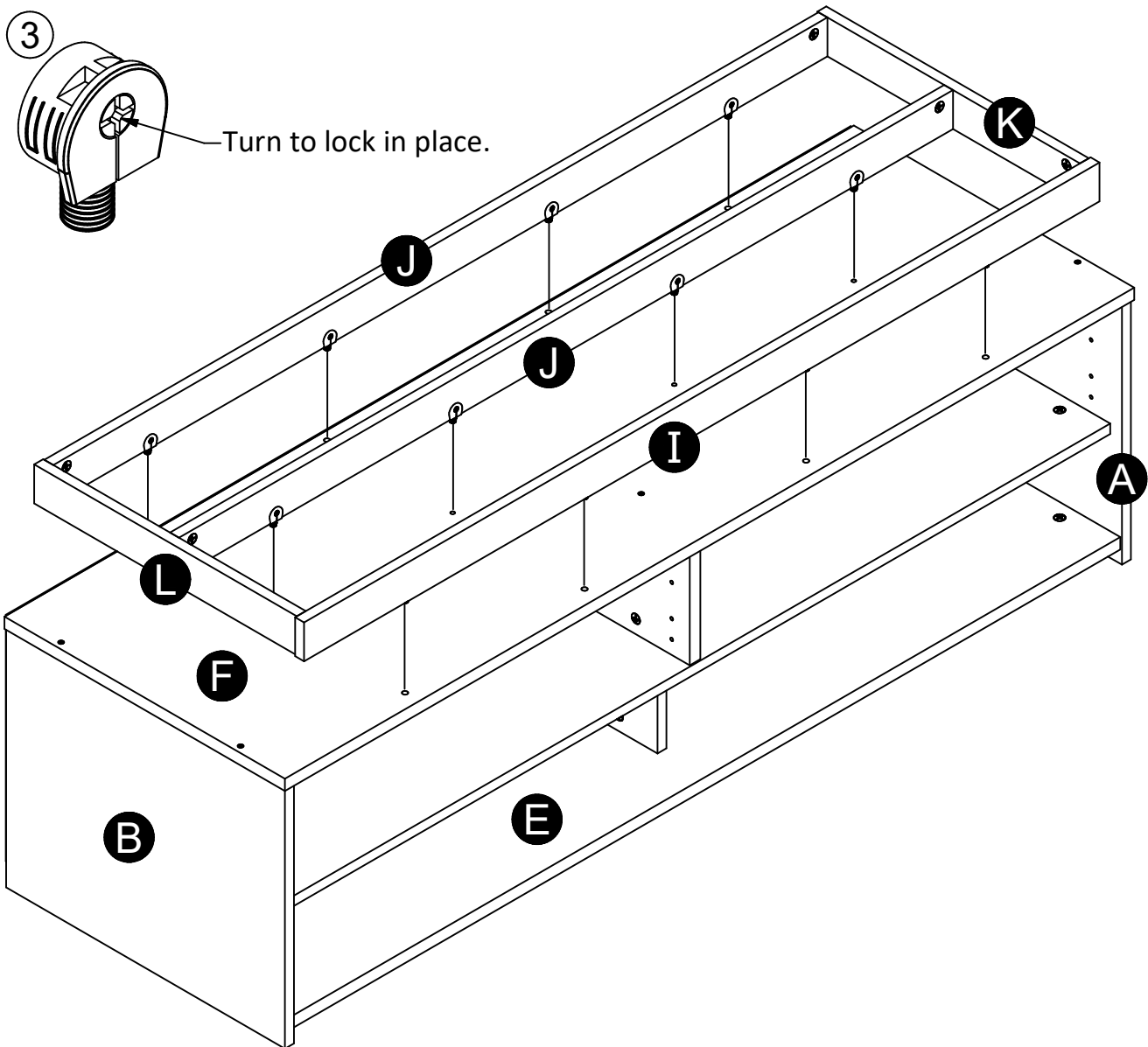

STEP 17

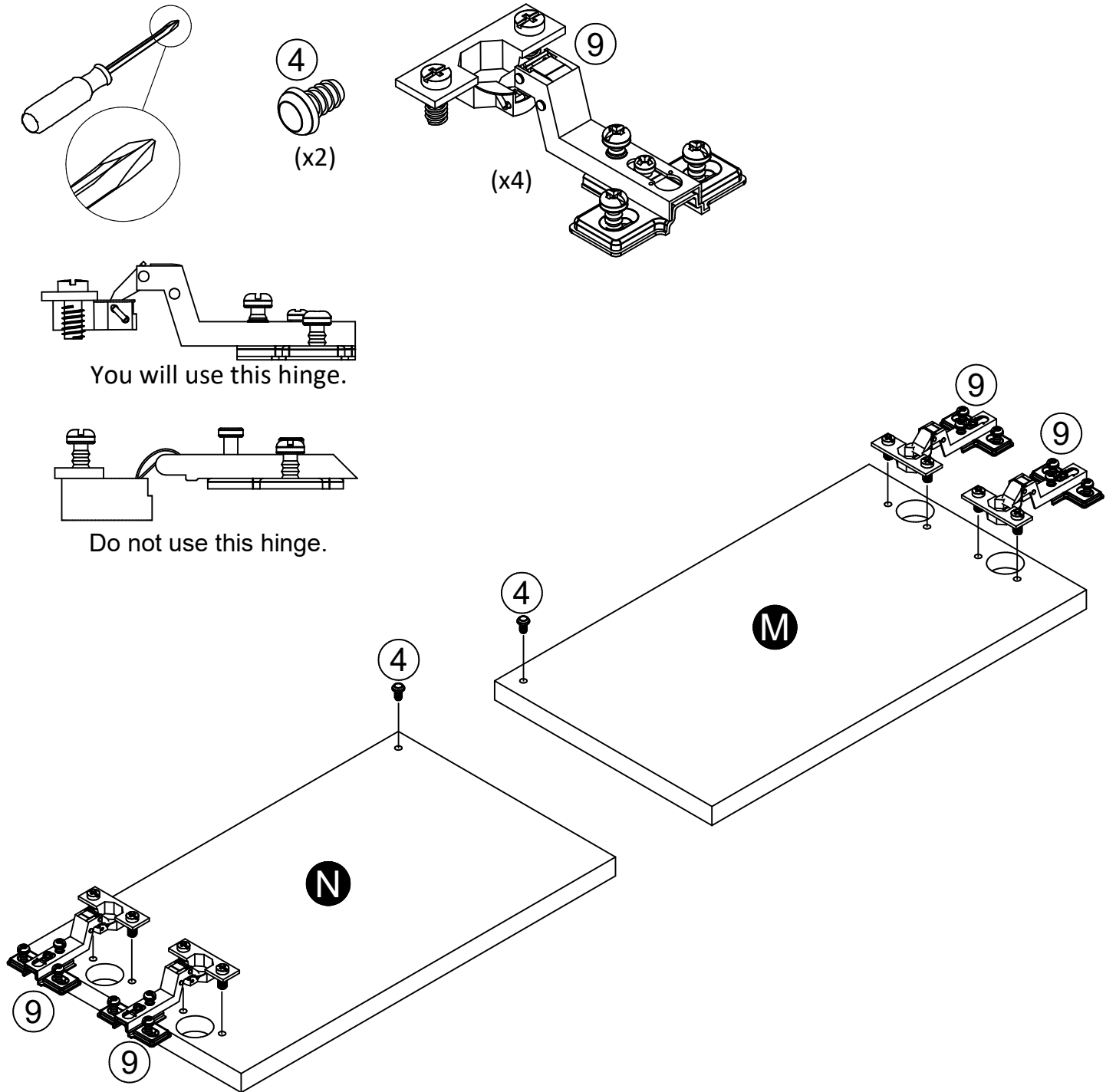

Locate the four inset hinges (9). Attach two hinges (9) to the left outer door (M) and right outer door (N) as shown. Press a door bumper (4) onto each door as shown.

STEP 18

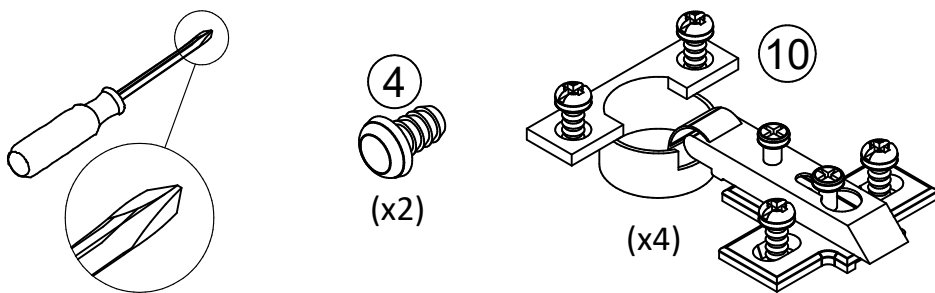

Attach the remaining hinges (10) and door bumper (4) to the left inner door (O) and right inner door (P) as shown.

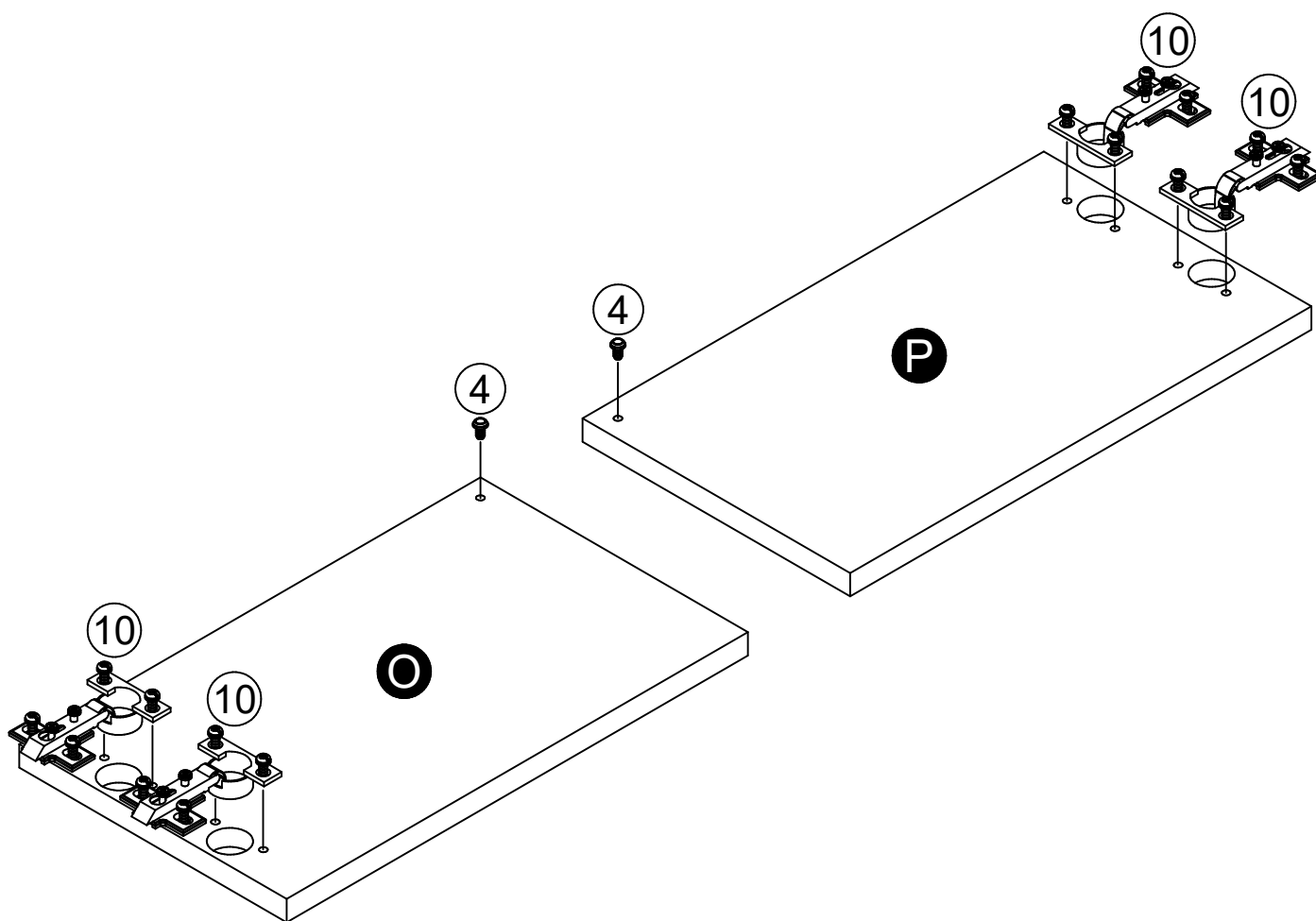

STEP 19

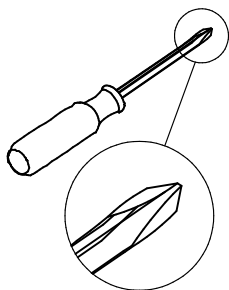

Mount doors as shown. Left outer door (M) will attach to the left panel (A). Right outer door (N) will attach to the right panel (B). The left and right inner doors (O&P) will mount to the lower partition (D).

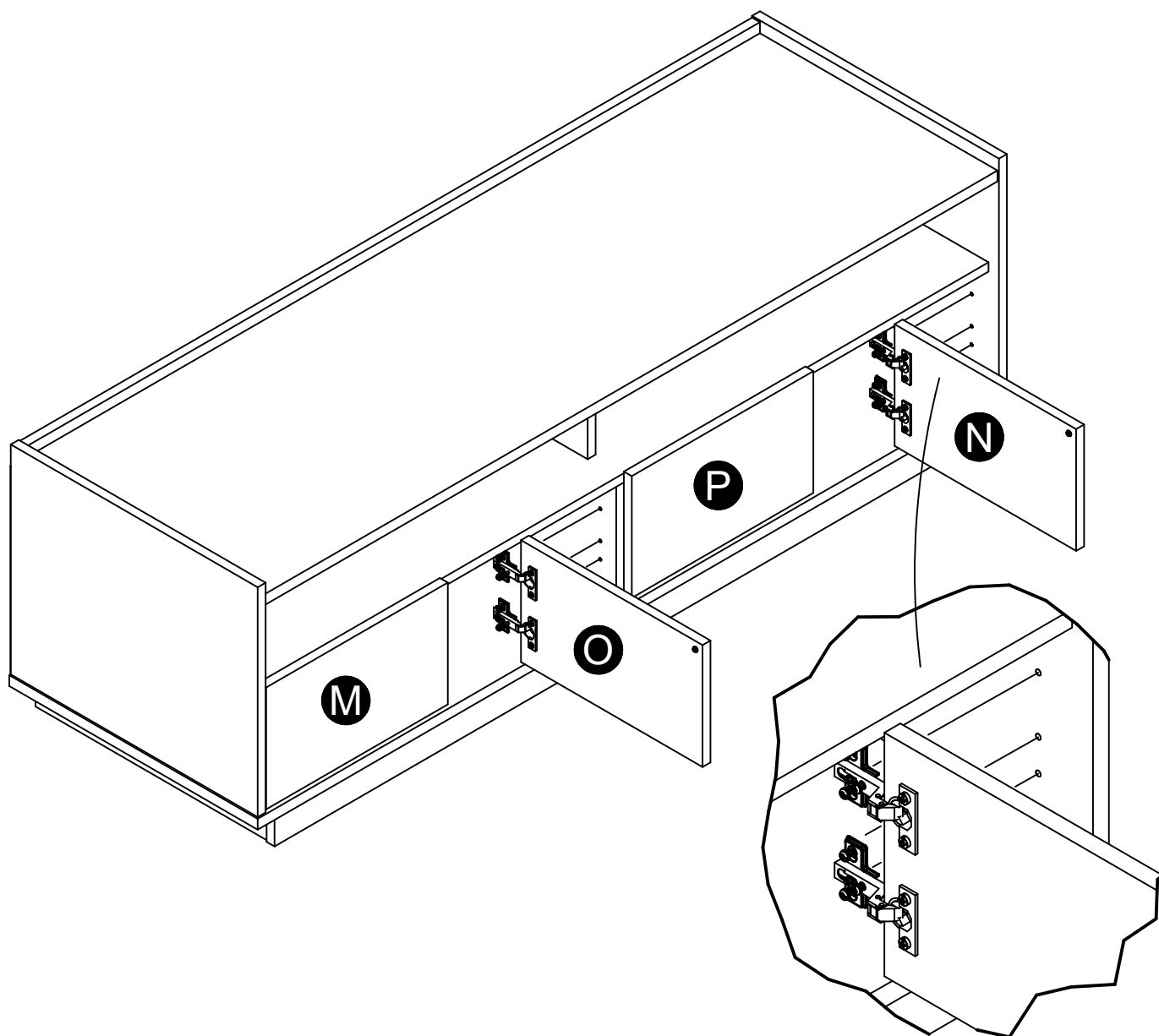

STEP 20

Door Adjustment

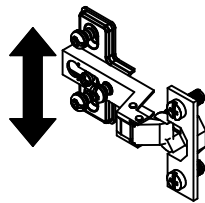
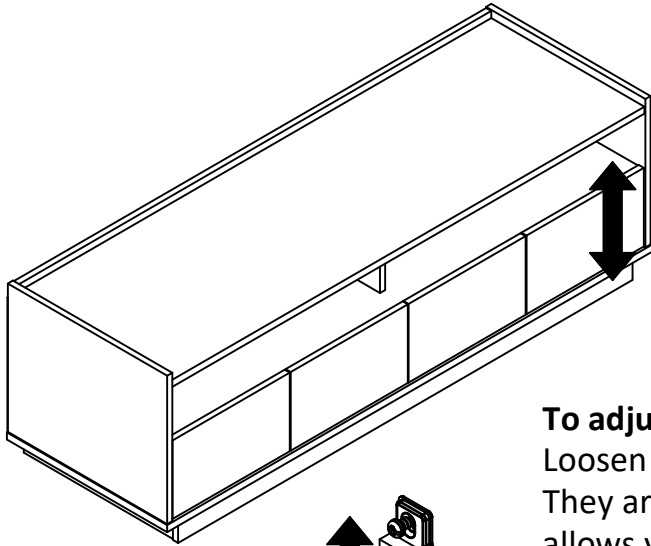
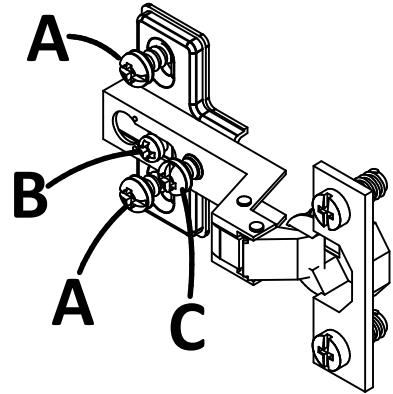

To adjust the vertical height:

Loosen the screws "A" on both hinges. They are usually in slotted holes which allows you to adjust up or down by a few mm. Then tighten back up.

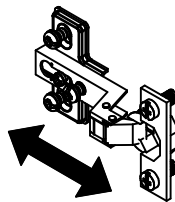
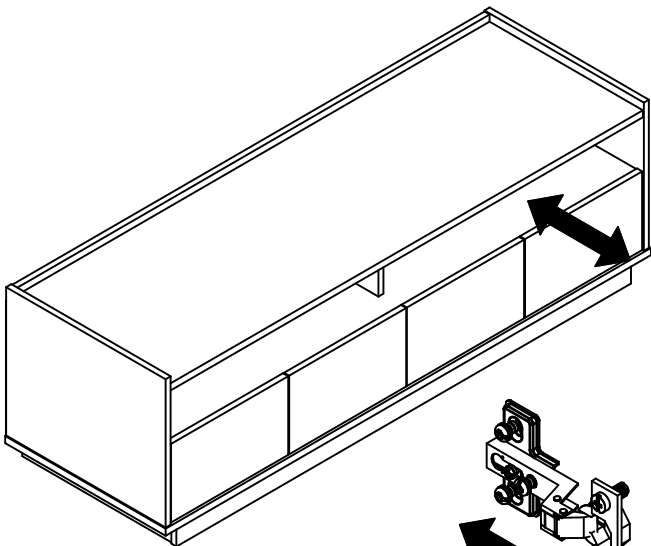

To adjust the depth:

Loosen the screw "B" and adjust door.

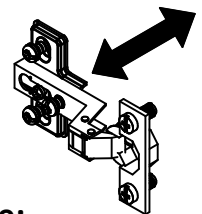
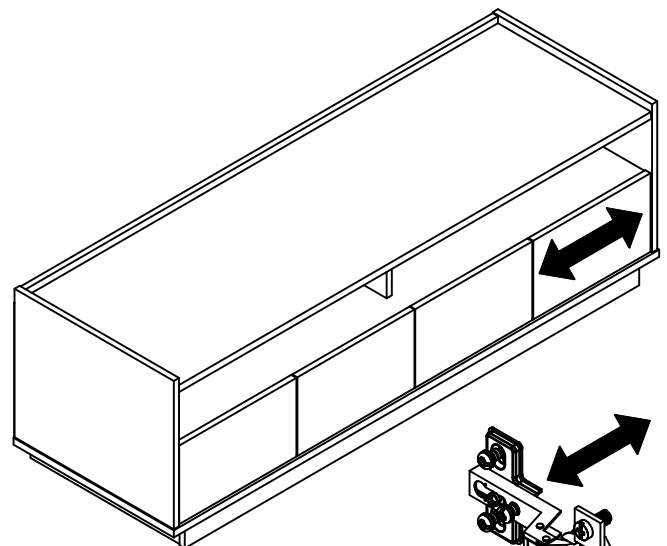

To adjust side to side:

Loosen the screw "C" on BOTH hinges and tighten "B" moves door outward. Loosen "B" and tighten "C" moves doors inward.

Maximum Loads

This unit has been designed to support the maximum loads shown. Exceeding these load limits could cause sagging, instability, product collapse, and/or serious injury.

Apply the TV Warning label to your unit for future reference.

NOTICE: Once applied to your model, you will not be able to remove it.

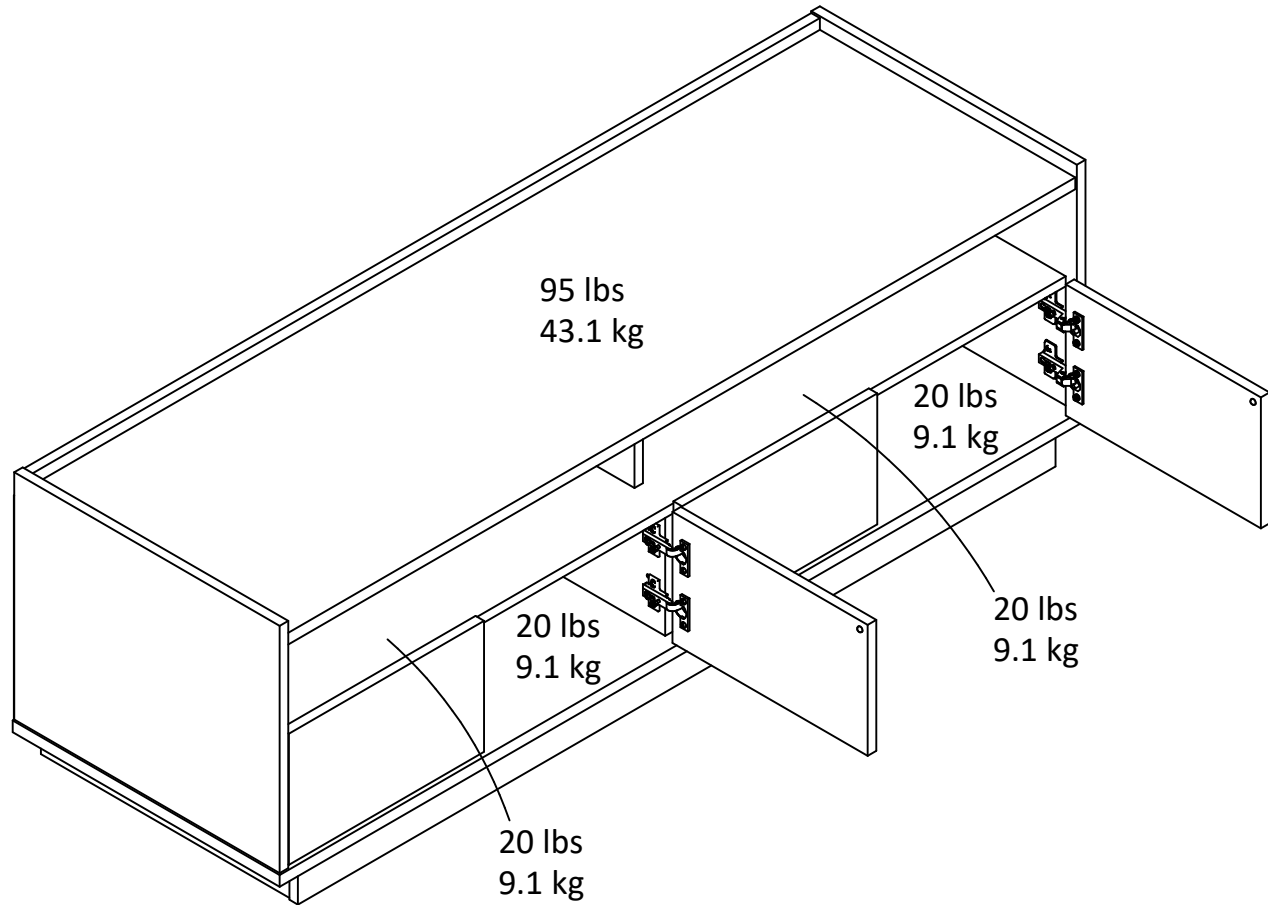

Certificate of Conformity

1. This certificate applies to the Dorel Home Furnishings, Inc. product identified by this instruction manual.
2. This certificate applies to compliance of this product with the CPSC Ban on Lead-Containing Paint (16 CFR 1303).
3. This product is distributed by: Dorel Home Furnishings, Inc.
410 East First Street South
Wright City, MO 63390
636-745-3351
4. Site of Manufacture: Tiffin OH
5. See front page of instruction manual for date of manufacture.

Register your product to receive the following:



- * New trend details - sneak peek on what's new
- * Surveys - have a voice within our community
- * Exclusive deals and discount codes
- * Quick and easy replacement part service

To register your product, visit ameriwoodhome.com

5 Star Rating



Visit your local retailer's website, rate your purchased product and leave us some feedback!

We would like to extend a big "Thank You" to all of our customers for taking the time to assemble this Ameriwood Home product, and to give us your valuable feedback.

*Thank
You!*

Español

Cubierta Delantera

Este libro de instrucciones contiene información **IMPORTANTE** de seguridad. Por favor lea y manténgalo para referencia en el futuro.

No Regrese este producto! Comuníquese con nuestro amistoso equipo de servicio al cliente para obtener ayuda.

Llámenos al: 1-800-489-3351 (Gratis) Lunes - Viernes 9am - 5pm CST

Visitar: www.ameriwoodhome.com

PRECAUCION

Este mueble puede volcarse y causar graves heridas y/o muerte.

Anclar el mueble a un poste de madera en la pared (si esto se requiere).

No Permita que los niños monten el mueble.

Mantenga los artículos más pesados en los cajones de abajo.

Consejos Útiles (página 2)

- Abra su artículo en el área donde usted planea utilizarlo para evitar levantar y moverlo menos
- Identificar, ordenar y contar las piezas antes de intentar ensamblar
- Las clavijas de compresión se golpean con un martillo
- Las diapositivas están marcadas con una R (derecha) y L (izquierda) para la colocación correcta
- Asegúrese de que siempre este el punto localizado en la parte superior de bloqueador de leva este volteado hacia borde exterior
- Utilizar todos los clavos para el panel de atrás y distribuirlos por igual
- El panel de atrás debe utilizarse para asegurarse de que la unidad quede fija y firme
- No use químicas fuertes ni limpiadores abrasivos en este artículo
- Nunca empuje, tire ni arrastre los muebles

Antes de Que Empieces (página 3)

- Lea cuidadosamente cada paso y siga el orden correcto

- Separar y contar todas sus piezas y hardware

- Dése suficiente espacio para el proceso de ensamble

- Tenga las siguientes herramientas: destornillador de cabeza plana, #2 cabeza Phillips

Destornillador y martillo

- Precaución: Si usa un taladro electrónico o un destornillador eléctrico para atornillar, por favor asegúrese que deje de atornillar cuando el tornillo este apretado. Fallar hacer esto puede causar barrer el tornillo.

Sistema de fijar el bloqueo de leva (página 3)

Este sistema de fijar el bloqueo de leva sera usado en todo el proceso ensamble.

Español

Página 12

Introduzca a presión cuatro tornillos tipo quick-lock (3) en los huecos en la parte superior (E). Con la corredera superior (H) apoyada horizontalmente con los huecos más grandes (4 huecos) mirando hacia arriba, presione la parte superior (E) contra la corredera superior (H) para que los tornillos tipo quick-lock (3) se ajusten dentro de los huecos. Gire los tornillos en sentido horario para unir las partes entre sí.

Página 18

¡IMPORTANTE! EL PANEL TRASERO ES UNA PARTE ESTRUCTURAL DE ESTA UNIDAD Y DEBE INSTALARSE DE MANERA ADECUADA

Con la ayuda de otra persona, gire la unidad y apóyela sobre el frente. Posicione el panel trasero tal como se muestra. Alinéelo sin desviaciones con los bordes de los paneles inferiores izquierdo y derecho. Usando tornillos (5), ajuste cada tornillo como se muestra, pero no ajuste por completo. Asegúrese de que el panel trasero esté alineado perfectamente y clávelo (6) directamente a los tres bordes, tal como se muestra. Ahora ajuste completamente los tornillos (5).

Nivele el borde inferior del panel trasero con el borde inferior del fondo (F).

Asegúrese de que la unidad esté perfectamente centrada. La distancia de esquina a esquina debe ser igual, tal como se muestra.

Página 22

Fije la corredera izquierda (K) y la corredera derecha (L) a las correderas posteriores (J) tal como se muestra y luego fije la corredera delantera (I) a las correderas izquierda y derecha (K&L).

Página 23

Con cuidado, posicione la unidad sobre su parte superior tal como se muestra. Posicione el componente de la corredera del paso anterior sobre el fondo (F) para que los tornillos tipo quick-lock (3) entren a presión en los agujeros y se ajusten en su lugar.

Página 24

Ubique las cuatro bisagras embutidas (9). Fije dos bisagras (9) a la puerta exterior (M) y a la puerta exterior derecha (N), como se muestra. Coloque a presión un tope (4) a cada puerta, tal como se muestra.

Página 25

Fije las bisagras restantes (10) y el tope de puerta (4) a la puerta interna izquierda (O) y a la puerta interna derecha (P), tal como se muestra.

Página 26

Monte las puertas tal como se muestra. La puerta externa derecha (M) se fijará al panel izquierdo (A). La puerta externa derecha (N) se fijará al panel derecho (B). Las puertas internas derecha e izquierda (O&P) irán montadas en la partición inferior (D).

Español

Página 27

Para ajustar la altura vertical:

Afloje los tornillos "A" en ambas bisagras. Suelen encontrarse en huecos ranurados, lo que permite subirlos o bajarlos por algunos milímetros. Luego vuelva a ajustarlos.

Para ajustar la profundidad:

Afloje el tornillo "B" y ajuste la puerta.

Para ajustar de lado a lado:

Aflojar el tornillo "C" en AMBAS bisagras y aflojar el "B" mueve la puerta hacia afuera. Aflojar el "B" y ajustar el "C" mueve la puerta hacia adentro.

Página 28

CARGA MAXIMA

Esta unidad fue diseñada para soportar las cargas máximas que se muestran. Exceder estos límites de carga podría causar hundimiento, inestabilidad, colapso del producto y/o lesiones graves.

Coloque la etiqueta de Advertencia de TV en su unidad para referencia futura.

RECUERDE: Una vez que la coloque en su modelo, no podrá quitarla.

Página 29

Registre su producto para recibir lo siguiente:

- * Detalles de nuevas tendencias - Vistazo a lo nuevo
- * Encuestas - aloc su voz entre su comunidad
- * Códigos de ofertas y descuentos exclusivos
- * Fácil y rápido servicio de partes de remplace

Para registrar su producto, visite ameriwoodhome.com

Clasificación de 5 estrellas

Visite el sitio web de su tienda local, califique su comprado y denos sus comentarios!

Nos gustaría enviar un gran "Agradecimiento" a todos nuestros clientes por tomarse el tiempo de ensamblar este producto de Ameriwood Home, y por darnos sus valiosos comentarios.

Gracias

Français

Couverture Avant

CE LIVRET D'INSTRUCTION CONTIENT DES INFORMATIONS **IMPORTANTES** SUR LA SÉCURITÉ. VEUILLEZ LIRE ET GARDER POUR UNE RÉFÉRENCE FUTURE

Ne retournez pas ce produit! Contactez notre équipe de service à la clientèle amicale d'abord pour obtenir de l'aide.

Appelez-nous: 1-800-489-3351 (sans frais) du Lundi au Vendredi de 9h à 17h Heure Centrale

Visitez: www.ameriwoodhome.com

ATTENTION

Le meuble peut basculer et causer des blessures graves ou la mort.

Ancrer le meuble à une planche murale dans le mur (si indiqué).

Ne laissez pas les enfants grimper sur le meuble.

Placez les articles lourds sur les étagères ou dans les tiroirs inférieurs.

Astuces Utiles (page 2)

-Ouvrez votre article dans la zone que vous prévoyez de le garder pour moins de levage lourd

-Identifier, trier et compter les pièces avant d'essayer d'assembler

-Les goujons de compression sont taraudés avec un Marteau

-Les glissières sont marquées d'un R (droit) et d'un L (gauche) pour un bon placement

-Assurez-vous toujours de faire face la pointe situé sur le haut de la Serrure de Came vers le bord extérieur

-Utiliser tous les clous fournis pour le panneau arrière et les répartir également

-Le panneau arrière doit être utilisé pour vous assurer que votre appareil est robuste

-N'utilisez pas de produits chimiques agressifs ou de nettoyants abrasifs sur cet appareil

-Ne jamais pousser, tirer, ou faire glisser votre meuble

Avant de Commencer (page 3)

-Lisez attentivement chaque étape et suivez le bon ordre

-Séparez et comptez toutes vos pièces et matériaux

-Donnez-vous suffisamment de place pour l'assemblage

-Avoir les outils suivants: tournevis à tête plate, #2 tournevis Phillips, et Marteau

-Attention: Si vous utilisez une perceuse électrique ou un tournevis électrique pour visser, veillez à ralentir et arrêter lorsque la vis est bien serrée. Le non-respect de cette consigne peut endommager la vis.

Système de Fixation de Came (page 3)

Ce Système de Fixation de Came sera utilisé tout au long de l'assemblage

Français

Page 12

Insérez quatre attaches quickloc (3) dans les trous de la section supérieure (E). Avec la rampe supérieure (H) à plat et les trous les plus grands (4 trous) vers le haut, insérez le dessus du meuble (E) dans la rampe supérieure (H) afin que les attaches quickloc (3) entrent dans les trous. Faites tourner les attaches dans le sens horaire pour verrouiller les parties en place.

Page 18

IMPORTANT! LE PANNEAU ARRIÈRE DE CETTE UNITÉ EST STRUCTUREL ET DOIT ÊTRE INSTALLÉ CORRECTEMENT

Avec l'aide d'une autre personne, faites basculer avec soin l'unité sur sa face frontale. Placez le panneau arrière tel qu'indiqué. Faites-le s'aligner précisément avec les tranches des panneaux inférieur, de gauche et de droite. À l'aide de vis (5), insérez chaque vis partiellement, tel qu'illustré. Ne les serrez pas complètement. Assurez-vous que le panneau soit bien aligné, puis clouez-le (6) perpendiculairement sur les trois côtés tel qu'illustré. Maintenant, serrez les vis complètement (5).

Alignez le côté inférieur du panneau arrière sur le côté inférieur du dessous (F).

Assurez-vous que tous les angles soient droits. La distance d'un coin à l'autre doit être égale, tel qu'illustré.

Page 22

Fixez la rampe de gauche (K) et la rampe de droite (L) aux rampes arrière (J) tel qu'illustré, puis fixez la rampe avant (I) aux rampes de gauche et de droite (K et L).

Page 23

Avec soin, faites basculer l'unité sur son côté supérieur, tel qu'illustré. Positionnez le rail inférieur assemblé à l'étape précédente sur le côté inférieur du meuble (F) de façon à ce que les attaches quickloc (3) entrent dans les trous et se verrouillent en place.

Page 24

Repérez les quatre charnières incrustées (9). Fixez deux charnières (9) à la porte extérieure gauche (M) et à la porte extérieure droite (N) tel qu'illustré. Fixez un butoir (4) sur chaque porte, tel qu'illustré.

Page 25

Fixez les charnières (10) et le butoir (4) restants à la porte intérieure gauche (O) et à la porte intérieure droite (P), tel qu'illustré.

Page 26

Assemblez les portes tel qu'illustré. La porte extérieure gauche (M) se fixera au panneau de gauche (A). La porte extérieure droite (N) se fixera au panneau de droite (B). Les portes intérieures de gauche et de droites (O et P) se fixeront à la section inférieure (D).

Français

Page 27

Pour ajuster la hauteur verticale:

Desserrez les vis « A » sur les deux charnières. Elles se trouvent normalement dans des trous oblongs qui vous permettent d'ajuster la hauteur de quelques millimètres. Resserrez après ajustement.

Pour ajuster la profondeur :

Desserrez la vis « B » et ajustez la position de la porte.

Pour ajuster latéralement :

Desserrez la vis « C » sur les DEUX charnières et serrez la « B » pour pousser la porte vers l'extérieur. Desserrez « B » et resserrez « C » pour pousser la porte vers l'intérieur.

Page 28

CHARGES MAXIMALES

Cette unité a été conçue pour supporter les charges maximales indiquées. Excéder ces limites de chargement pourrait entraîner l'affaissement, l'instabilité ou l'effondrement du produit et/ou des blessures graves.

Appliquez l'étiquette de mise en garde télé sur l'unité pour référence future.

AVIS : Une fois appliquée à votre modèle, vous ne pourrez pas l'en retirer.

Page 29

Enregistrez votre produit pour recevoir les éléments suivantes:

- * Détails sur les nouvelles tendances - un aperçu sur les nouveautés
- * Sondages - avoir une voix au sein de notre communauté
- * Offres exclusives et codes promo
- * Service de pièces de rechange rapide et facile

Pour enregistrer votre produit, visitez ameriwoodhome.com

5 Étoiles

Visitez le site Web de votre détaillant local, évaluez votre produit acheté et laissez-nous quelques commentaires !

Nous tenons à offrir un grand "Merci" à tous nos clients pour avoir pris le temps d'assembler ce produit "Ameriwood Home", et de nous donner vos commentaires précieux.

Merci